

Tuner Manual

AiM ECUs and Spark software

Release 1.11

AiM Offroad ECUs



SPARK Tuner



User Guide



INDEX	0
1 – Introduction	4
2 – AiM off road ECUs connectors	5
3 – Compatibilities	5
4 – Accessories: Handlebar Switch and UC Bridge	6
4.1 – Handlebar switch	7
4.1.1 – How to change Maps:	7
4.1.2 – How to apply corrections:	7
4.1.3 – How to use Traction Control:	8
4.1.4 – How to activate Launch Control:	8
4.1.5 – Configure the Handlebar Switch as a Shift Light Module:	8
4.2 – UC Bridge	10
5 – ECU Available Configurations	10
6 – Spark Software	11
6.1 – Software overview	11
6.2 – Menu bar	12
6.2.1 – File	12
6.2.2 – ECU	15
6.2.3 – Configuration	15
6.2.4 – Map	16
6.2.5 – Live Measures	17
6.2.6 – Diagnostics	18
6.2.7 – Updates	19
6.2.8 – Options	21
7 – Icon bar	23
8 – Project view	24
8.1 – Configuration	25
8.1.1 – Parameters	26
8.1.1.1 – Motorcycle Setup	26
8.1.1.2 – Dashboard (Yarara only)	26
8.1.1.3 – Sensor Plausibility	27
8.1.1.4 – Timers	28
8.1.1.5 – Map switch	29
8.1.1.6 – Launch Control	29
8.1.1.7 – Pre-injection	31
8.1.1.8 – RPM Limiter	31
8.1.1.9 – Speed and gears settings (Yarara only)	32
8.1.1.10 – Speed limiter	32
8.1.1.11 – Strategies	33
Barometric calculation	33
Drop sensor	34
Fan control (Enduro bikes and ATV only)	35
Idle motor (Yarara only)	36
Injection strategy	40
Injectors phase strategy	41
Lean angle sensor (ATV only)	42
Neutral strategy	43
Quick shift	43
8.1.1.12 – Vb out	44
8.1.2 – CAN Configuration	45
8.1.2.1 – CAN parameters	45
8.1.3 – Sensors	45
8.1.3.1 – Spare channel #1 and #2	46
8.2 – Maps	46
8.2.1 – Fuel	47
8.2.1.1 – Injection main #1	47
8.2.1.2 – Fuel injection user compensation table	48
8.2.1.3 – Injection main speed-density (ms)	50



8.2.1.4 – Injection crank correction (%)	51
8.2.1.5 – Pre-injection (ms)	52
8.2.1.6 – Compensations	53
Injection BAP correction (%)	53
Injection EWT correction (%)	53
Injection IAT correction (%)	54
8.2.1.7 – Injector 1	54
Injector 1 battery correction (ms)	54
Injector 1 phase (phase°)	55
8.2.1.8 – Injector 2	55
Injector 2 battery correction (ms)	55
Injector 2 percentage (%)	56
Injector 2 phase (phase°)	56
8.2.1.9 – Transient	57
Injection opening transient correction.	57
Injection closing transient correction	57
8.2.2 – Ignition	58
8.2.2.1 – Ignition main #1 alpha-n (Advance)	58
8.2.2.2 – Ignition user compensation	59
8.2.2.3 – Ignition dwell time (Taipan Y/Yarara only)	59
8.2.2.4 – Compensations	60
Ignition BAP correction (Advance°):	60
Ignition EWT correction (Advance°)	61
Ignition IAT correction (Advance °)	61
8.2.2.5 – Transient	62
Ignition opening transient correction	62
Ignition closing transient correction	62
8.2.3 – Launch control	62
8.2.3.1 – Injection launch control main table (ms)	63
8.2.3.2 – Ignition launch control main table (Advance (°))	63
8.2.4 – Traction control	64
8.2.4.1 – Traction control strategy	65
8.2.4.2 – Activate the traction control strategy	66
8.2.4 – Quick shift	67
8.2.4.1 – Quick shift cut timetable (ms)	67
8.3 – Expansions	68
9 – Data view – special key and visualization	69
9.1 - Table Format	69
9.2 – 2D Format	70
9.3 – 3D Format	71
10 – Live Measures view box	72
11 – Info bar	73
Appendix A – AiM ECUs ECU Part Numbers	74
Appendix B – AiM ECUs and accessories dimensions and pinout	75
Taipan and Taipan Y dimensions in mm [inches]	75
Yarara dimensions in mm [inches]	76
Handlebar Switch dimensions in mm [inches]	77
UC Bridge dimensions in mm [inches]	78
Taipan pinout	79
Taipan Y pinout	80
Yarara pinout	81
Handelbar Switch pinout	82
UC Bridge pinout	83
Appendix C – Taipan, Taipan Y and Yarara harnesses	84
Taipan and Taipan Y optional cables dimensions and pinout	84
Yarara optional cable dimensions and pinout	86
AiM ECUs CAN+External power cable for Solo 2 DL dimensions pinout	87
Appendix D – Main terms	88



Appendix E – Pre-injection	90
Appendix F – Injection crank correction (%)	92
Appendix G – Injection N battery correction	96
Appendix H – Injection BAP correction	97
Appendix I – Transient management	98
Appendix J – CAN Protocols	105
Appendix K – Malfunctioning Indicator Lamp (MIL) – Taipan only	109

1 – Introduction

Taipan/Taipan Y and Yarara are the AiM ECUs designed for off-road bikes.



Their **part numbers** are:

- Taipan
- Taipan Y
- Yarara

XE1ECUCBO
XE1ECUCB1
XE1ECUYA0

Each ECU can have **optional accessories** as follows:

- Handle Bar switch
- CAN UC Bridge Tuner version

XE1HBS000
XE1UCBT00

Additional cables or harnesses are also available

- All ECUs 2m extension cable
- All ECUs 4m extension cable
- 50cm extension cable for connection with Solo 2 DL
- Analog channels and second injection harness
- Analog channels harness
- Second Injection harness
- Yarara additional harness

V02596020
V02596030
V02589120
V02596060
V02596070
V02596080
V02596090

Please refer to "Appendix "C for further information about ECUs accessories, cables and harnesses.

All ECUs are easily installable on most of the off-road bikes, as described in Chapter 3.

2 – AiM off road ECUs connectors

AiM ECUs ECU have four connectors:

- the main connector, compatible with most of the off-road bikes
- a CAN connector, to be connected to the Handlebar Switch and to an external datalogger.
- a second CAN connector, to be connected to the UC Bridge in order to communicate with the PC.
- a fourth connector, to be connected to spare sensors and eventually to a second injector.

Yarara ECU has two connectors:

- the main connector, compatible with most of the off-road bikes
- a CAN connector, for Yarara optional harness that allows connection with
 - UC Bridge
 - Handlebar Switch (HBS)
 - an external datalogger
 - other expansions

Please note: AiM off road ECUs and accessories dimensions and pinout are described in Appendix B.

3 – Compatibilities

AiM off road ECUs, Spark tuning software and accessories, are compatible with many model brands and types; please refer to Taipan page, compatible models of AiM website at www.aim-sportline.com. This list is constantly updated.

4 – Accessories: Handlebar Switch and UC Bridge

AiM off roads ECU have these accessories:

- Handlebar switch: the fastest way to apply strategies while riding.
- UC Bridge: an USB to CAN dongle used for AiM off road ECUs-Spark tuning software communication.

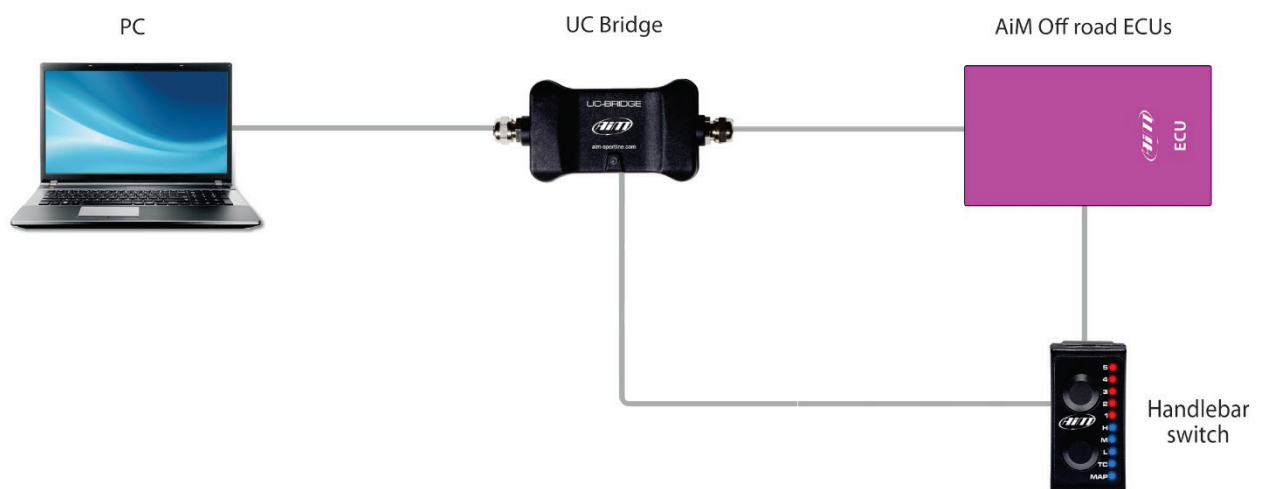

4.1 – Handlebar switch



The Handlebar Switch is the best way to change the behavior of your motorcycle; it features 2 pushbuttons and 10 LEDs and manages the following settings:

- Running map change
- Fuel corrections
- Traction control activation
- Launch control activation.

The lower pushbutton is used to select a feature while the upper pushbutton is used to choose one of the available options in the selected feature.

Finally, as described in section 4.1.5, you may use the LEDs on the handlebar switch as a Shift Light Module: in this case, at the desired RPM value the LEDs will start blinking, helping you changing gear.

When the ECU is powered ON Handlebar Switch will display the running map. The example to the right shows that map 2 is the running one.



4.1.1 – How to change Maps:

To change the running map:

- push the lower button until when the MAP Led is enlightened in blue
- push the upper button for changing the running map
- if the selected map is valid the respective LED will remain lit; else it will return to the previously selected valid map.

4.1.2 – How to apply corrections:

Correction is the possibility to get a richer/leaner fuel mixture at different RPM ranges: low, mid, high. The RPM thresholds as well as the percentage to apply along with the default value, are defined in a proper chapter in this manual (configuration-parameters- map switch – injector trims 8.2.5). To apply a correction:

- push the lower pushbutton to select at which RPM range (lower, mid, or high) you want to set the correction.
- use the upper button to set it:
 - Select Level 3 for No Correction
 - Select Level 4 and 5 for a fatter mixture.
 - Select Level 1 and 2 for a leaner mixture.

4.1.3 – How to use Traction Control:

Traction control is a system that aids in preventing driven wheel spin when excess power is applied. To activate it:

- keep pushed the lower button until the green LED beside the TC turns ON; if you want to de-activate it, press and hold the lower pushbutton again until the green LED turns OFF.
- With the TC enabled, use the upper pushbutton to select the strength of the Traction Control strategy with 1 being the minimum and 5 being the maximum.

Please note that Traction Control must be enabled for the selected Map: this will be done during the ECU Map configuration.

4.1.4 – How to activate Launch Control:

Launch control is an electronic aid to assist riders to accelerate from a standing start.

To activate it press and hold both upper and lower pushbuttons until the LEDs blink red, indicating that the strategy is engaged.

Please note: Launch Control must be enabled in the selected map.

4.1.5 – Configure the Handlebar Switch as a Shift Light Module:

A Shift light module is an array of LEDs that will begin flashing at a defined RPM value, aiding the rider to choose the optimal shift points. You may use the Handlebar Switch LEDs as a Shift Light after configuring as shown here. Please, connect and link the HBS to the UC Bridge through the CAN Connection.



- Open a new project and select the HBS image from Create blank project menu as shown below.



After the selection you will see this project tree:

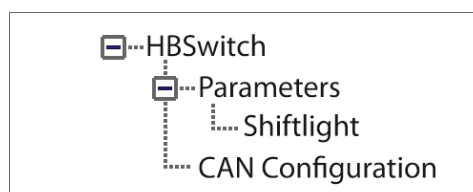

Please, do not forget to click "Connect" Icon.

Shift light:

Shift lights Enabled: true or false, to set up if you want to have the shift lights on your HBS or not.
Shift lights RPM threshold: to set up the RPM value at which the LEDs will flash.

After configuring the Handlebar Switch connect it to the ECU expansion connector.

4.2 – UC Bridge



The **UC Bridge** is the connection between the CAN bus of the ECU and the USB port of your PC and is available with 2 different licenses:

- **User license:** an AiM ECU comes with some basic maps that already give you performances better than the stock ones. All over the world some highly professional tuners offer specific maps that may better fit your requirements managing, for example, different exhaust systems, two injector kits, etc. You need UC Bridge to:
 - transfer new and different maps to your ECU through the User License UC Bridge
 - receive diagnostic information from AiM ECU
- **Tuner license:** with this license tuners can create maps, configurations and strategies designed for the riders motorcycle. The tuner can flash the ECU directly or send the file by email to allow the rider downloading and flashing their own ECU. All while preserving the tuners proprietary work with three layers of protection and security. The tuner can flash the files directly to the ECU or send them by e-mail to allow the rider downloading and installing all Maps in the ECU. This manual covers the use of the tuner license.

5 – ECU Available Configurations

AiM ECUs ECU is available in two different configuration statuses:

- **Configured ECU:** an already configured ECU is dedicated to the desired brand and model motorcycle. You may change maps and configurations but cannot change motorcycle brand or model.
- **Blank ECU:** a Blank ECU can be configured for the brand/model motorcycle you desire, simplifying the stock management of the tuners. **Be Careful!** Once you have configured a blank ECU for a dedicated model of motorcycle, you can no longer change the model of the motorcycle. In case you set the wrong model you must send the ECU back to your AiM distributor that will restore the ECU as blank and reconfigure it correctly for the proper model. AiM ECUs are normally shipped blank. To know if your ECU is blank or configured run Spark software and follow this path "Diagnostics -> Read ECU Identity".

6 – Spark Software

Spark is the AIM software used to configure and calibrate AiM ECUs. This document explains in detail each available function you can use with this software with a “tuner” license. To use the software, you must connect at least UC Bridge, otherwise you cannot create projects nor use all the functionalities of Spark.

Connecting UC Bridge tuner licence and the ECU to the PC you can create, read projects, write, and flash the ECU.

6.1 – Software overview

When you open the Spark software with UC Bridge connected, the first window appears as in the following picture. The six macro-areas here highlighted will be referred to as indicated here on the right. The following chapters describe each area in detail.

- **Black** Menu bar (1)
- **Red** Icon bar (2)
- **Green** Project view (3)
- **Violet** Data view (4)
- **Blue** Live Measures view box (5)
- **Orange** Info bar (6)

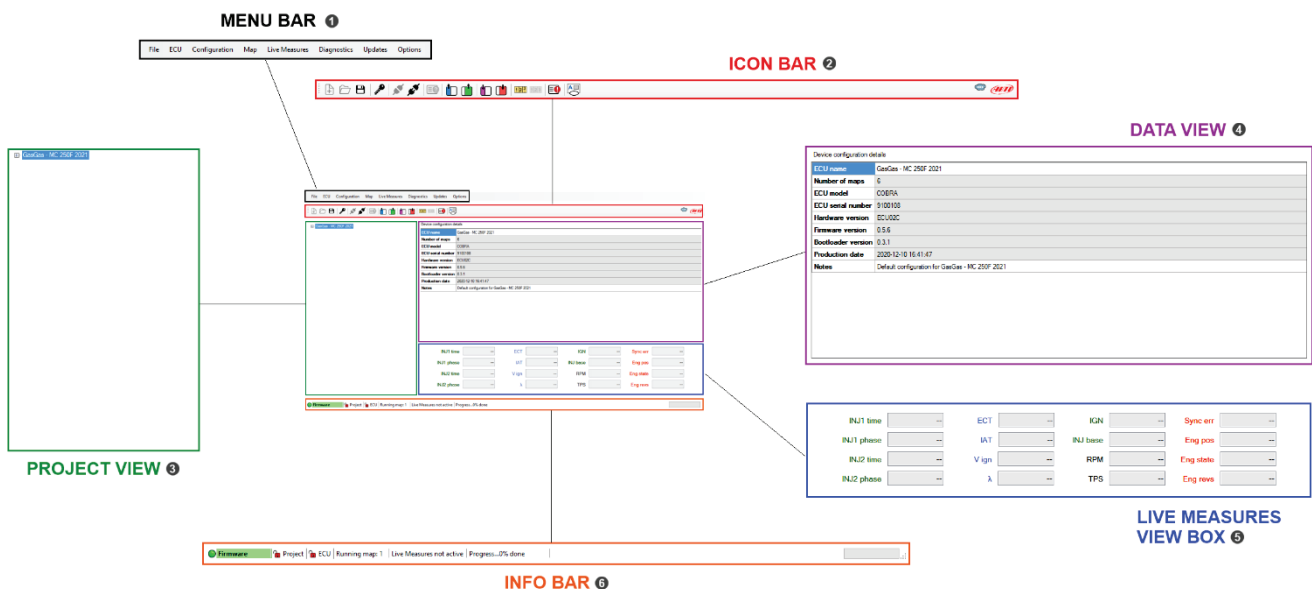

6.2 – Menu bar

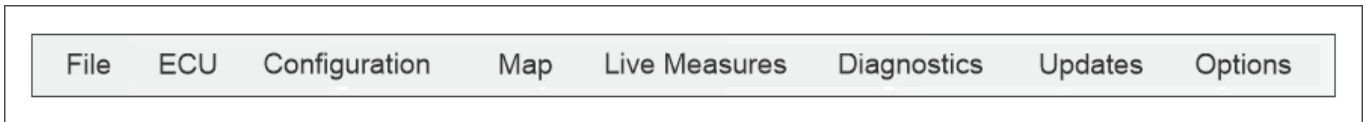

This bar features all the available items that allow to manage the project, setup the ECU, monitor data. Each item includes several functions here below listed. **Please note that:**

- **Connected** is intended to mean “physically connected”: an ECU is “connected” to the PC when is connected to the UC Bridge and this last is connected to your PC.
- **Linked** means that the communication between PC and device is activated: this is done clicking  icon on the icons bar.

6.2.1 – File

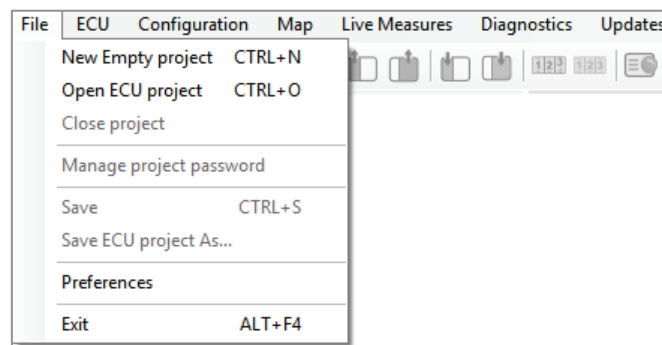

New Empty project: using this command you can create a new project, that is the sum of configuration, maps, strategies and other parameters. A list of available motorcycles will appear after the selection and selecting one of them you will be able to start.

Please note: you can create a project without connecting the ECU but the UC Bridge must be connected to the PC.



This is the menu that will appear after the selection of starting a new project, then you can select the motorcycle type or the Handlebar Switch configuration.

- **Open ECU project:** opens a previously saved project
- **Close project:** closes the open project
- **Duplicate project:** duplicates a project into another compatible motorbike.

Please note: You need to make sure that the two motorbike/ATV models for which you are duplicating the project are compatible in terms of configuration and maps! AiM does not take any responsibility for failure due to this feature.

- **Manage project password (shortcut icon ).** The tuner that has developed a project may protect it with a password: when a protected project is sent to a customer, only who has the password may open and eventually modify it.

The tuner that develops a project may decide to give the possibility to send it to one ECU only or to some ECU(s): in this case, he needs to create a crypted version of the project, depending upon the SERIAL NUMBER of the ECUs that may receive it.

In "Manage ECU target list" area you can add or delete a target ECU using its serial number.

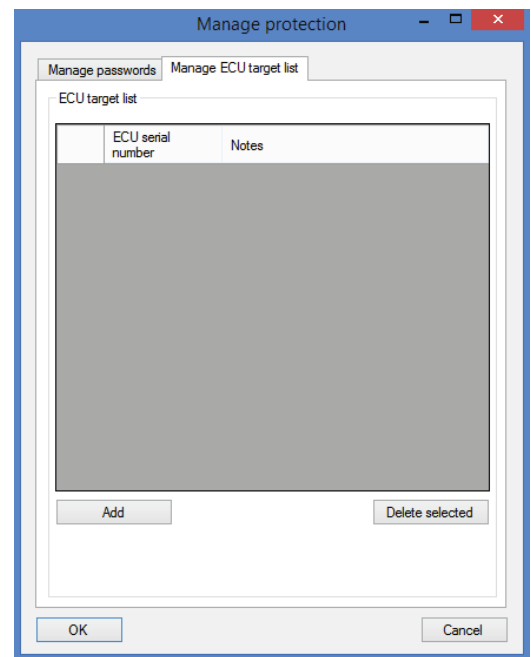
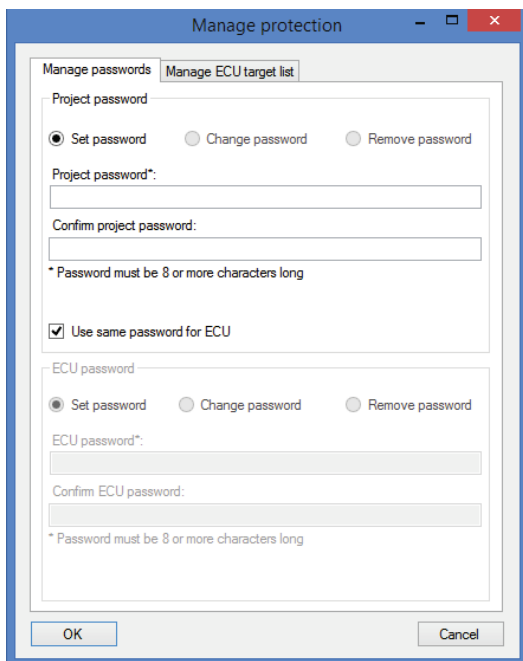

If a password is set when the project is reopened the password will be requested.

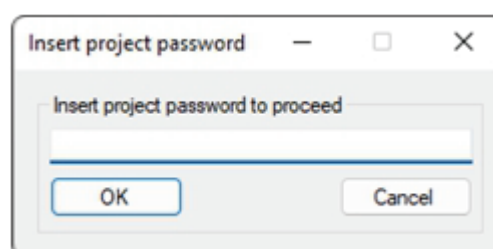

- **Save:** to save the current project
- **Save ECU project As...:** to save a copy of the current project with a new name.
- **Preferences:** To set up your country measurement units.

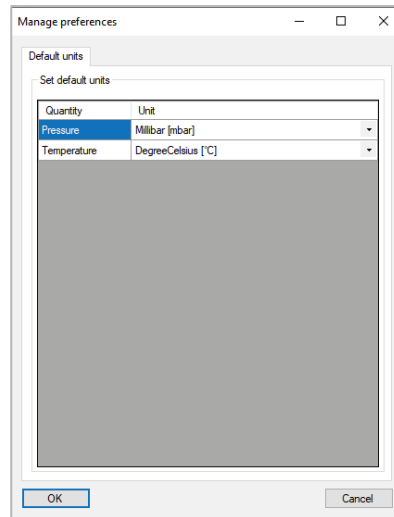

- **Exit:** to close Spark.

6.2.2 – ECU

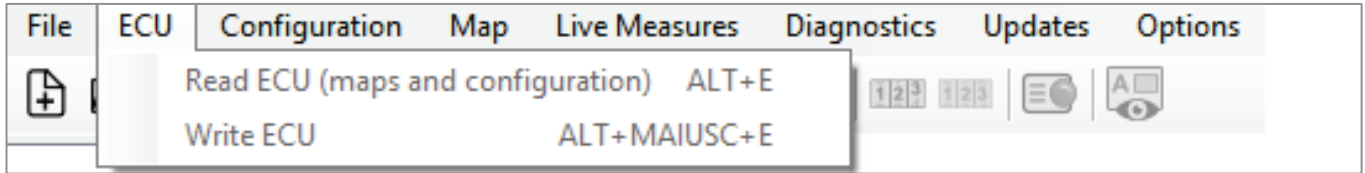

Read ECU (maps and configuration): this command is used to read from the ECU all the maps and the configurations flashed in. To do so follow these steps:

- open a project selecting the proper motorcycle
- connect and link the ECU
- read the ECU.

Please note: the ECU comes with the base map OPEN. If you have a Tuner UC Bridge you may read and modify the ECU as you wish. If the ECU stores maps produced by professional tuners and reasonably protected by a password you are required to set the proper password to read them.

Write ECU: This command is used to flash the configuration and maps selected into the ECU with the dedicated menu shown here below on the right; it appears executing this command.

Two different CAN protocols are available:

- Tuner CAN Protocol
- User CAN Protocol

Both are fully described in Appendix J.

The first one, **Tuner CAN Protocol**, is used when you need to send all the possible information managed by the ECU (66 channels) to the logger and is useful when you are tuning a motorcycle. The second one, **User CAN Protocol**, only transmits the most important channels (28 channels) and is to be chosen when you flash a configuration into the ECU of the customer.

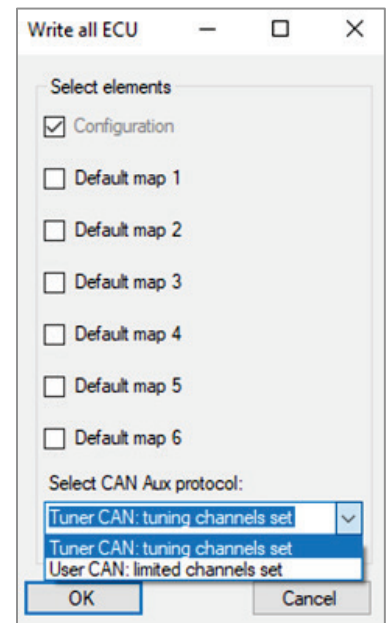

6.2.3 – Configuration

Read configuration from ECU: this command is used to read the configuration from the ECU.

Write configuration to ECU: this command is used to flash the configuration in the ECU.

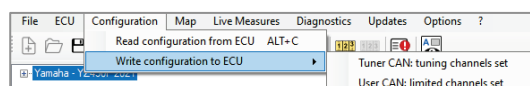

6.2.4 – Map

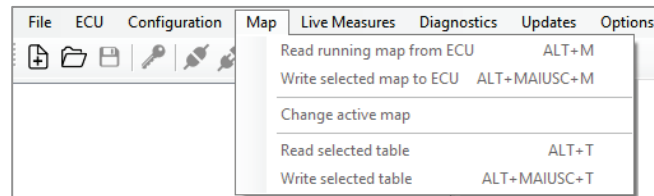

Read running map from ECU: this command is used to read the running map only.

Write selected map to ECU: this command is used to flash the desired map into the ECU. After having selected this feature, the following image appears.

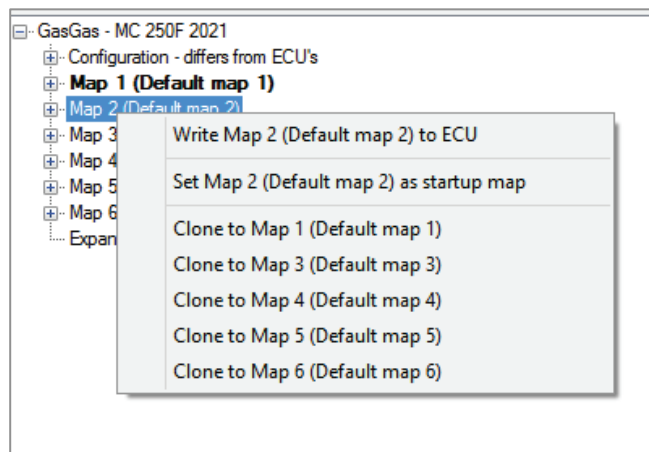

- select the desired map through the right click of your mouse.
- select the menu voice “Write Map”.

Finally, you can **clone the map** on other maps, for future developments.

Change active map: the active map (the map that is currently running) can be changed choosing from a proper selection menu.

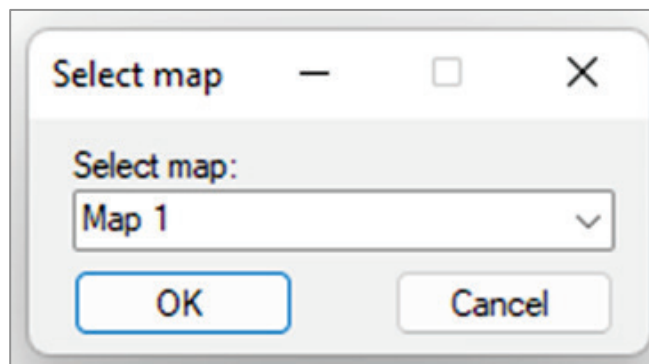

Read selected table: a selected table can be read from the running map.

Write selected table: the selected table can be written to the running map.

6.2.5 – Live Measures

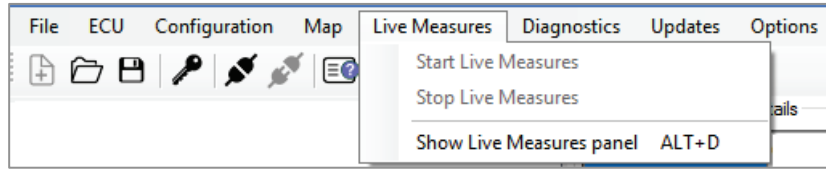

Start Live Measures: this option is used to start Live Measures in Live Measures view box, once the project is opened and the ECU connected.

Device configuration details

ECU name	GasGas - MC 250F 2021
Number of maps	6
ECU model	COBRA
ECU serial number	9100108
Hardware version	ECU02C
Firmware version	0.5.6
Bootloader version	0.3.1
Production date	2020-12-10 16:41:47
Notes	Default configuration for GasGas - MC 250F 2021

INJ1 time	3.344 ms	ECT	70.0 °C	IGN	9.0 °	Sync err	0 #
INJ1 phase	-92.0 °	IAT	20.0 °C	INJ base	0.760 ms	Eng pos	Seek
INJ2 time	0.000 ms	V ign	0.000 V	RPM	0 rpm	Eng state	Stop
INJ2 phase	-360.0 °	λ	0.000 λ	TPS	0.0 %	Eng revs	0 #

Measures active | Progress...0% done | Live Measures correctly started

Stop Live Measures: stops live measures in Live Measures view box.

Hide Live Measures panel: hides Live Measures view box and expands the data view area just above.

Show Live Measures panel: Shows Live Measures view box.

6.2.6 – Diagnostics

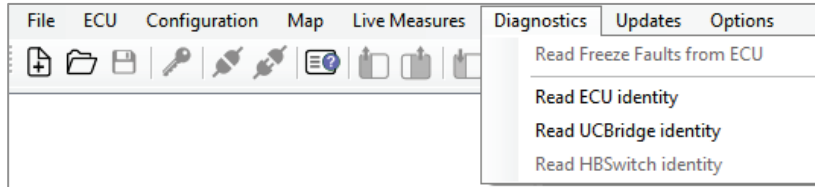

Read Freeze Fault from ECU:

Once the project is open and the ECU linked, it is possible to read the diagnostic data in real time or after a session and check the faults of engine and sensors. Saved faults can be exported in a “.csv” report file or deleted.

Clicking the command, two tabs appear. The Live faults tab (real time data) and Freeze faults tab (errors saved).

Diagnostics	State
Injector 1 - Open Load	Ok
Injector 1 - Over Current	Ok
Injector 1 - Over Temperature	Ok
Injector 1 - Short to Ground	Ok
Fuel Pump - Open Load	Ok
Fuel Pump - Over Current	Ok
Fuel Pump - Over Temperature	Ok
Fuel Pump - Short to Ground	Ok
MIL led - Open Load	Ok
MIL led - Over Current	Ok
MIL led - Over Temperature	Ok
MIL led - Short to Ground	Ok
MAP sensor signal low	Ok
MAP sensor signal high	Error
TPS sensor signal low	Ok
TPS sensor signal high	Error
Battery voltage signal low	Ok
Battery voltage signal high	Ok
ECT sensor signal low	Ok
ECT sensor signal high	Error
Gear sensor signal low	Ok
Gear sensor signal high	Error
IAT sensor signal low	Ok
IAT sensor signal high	Error
Drop sensor signal low	Ok
Drop sensor signal high	Ok

Time (hh:mm:ss)	Description
00:00:00	IAT sensor signal high
00:00:00	Gear sensor signal high
00:00:00	ECT sensor signal high
00:00:00	TPS sensor signal high
00:00:00	MAP sensor signal high

If Live Measures view box is activated, you can visualize the faults in real time. To activate Live Measures, press Start Live Measure icon

To save the faults in a CSV file press the bottom-right button

To clear the faults list, press the bottom-left button

Read ECU/UC bridge identity: reads serial number, firmware version and hardware versions of both ECU and UC bridge. This is an important info to maintain software and devices aligned.

Read Handlebar Switch identity: read serial number, firmware, and configuration from Handlebar Switch (if HB connected).

Here is the list of the possible sensor errors, coming from the ECU, that can be recognized by Spark (Injector 2 errors are present if injector 2 is available and enabled):

- Injector 1 – Open Load
- Injector 1 – Over Current
- Injector 1 – Over Temperature
- Injector 1 – Short to Ground
- Fuel Pump – Open Load
- Fuel Pump – Over Current
- Fuel Pump – Over temperature
- Fuel Pump – Short to ground
- MIL led – Open load
- Mil led – Over current
- Mil led – Over Temperature
- Mil led – Short to ground
- MAP sensor signal low
- MAP sensor signal high
- TPS sensor signal low
- TPS sensor signal high.
- Battery voltage signal low.
- Battery voltage signal high.
- ECT sensor signal low.
- ECT sensor signal high.
- Gear sensor signal low.
- Gear sensor signal high.
- IAT sensor signal low.
- IAT sensor signal high.
- Drop sensor signal low.
- Drop sensor signal high.

6.2.7 – Updates

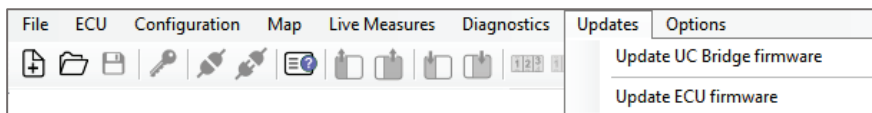

Update UC Bridge firmware: with **the project closed and the UC Bridge connected** you can update the firmware. First check if an update is available (icon on the right – icon section ). If it is you can download and install it in this section.

Update ECU Firmware: with **the project closed and ECU the connected** you can update the firmware. First check if an update is available (icon on the right – icon section). If it is you can download and install it in this section.

Update Handlebar Switch Firmware: This section appears only if HB Switch is connected to the UC Bridge. With **the project closed and HBS connected** you can update the firmware. First check if an update is available (icon on the right – icon section). If it is you can download and install it.

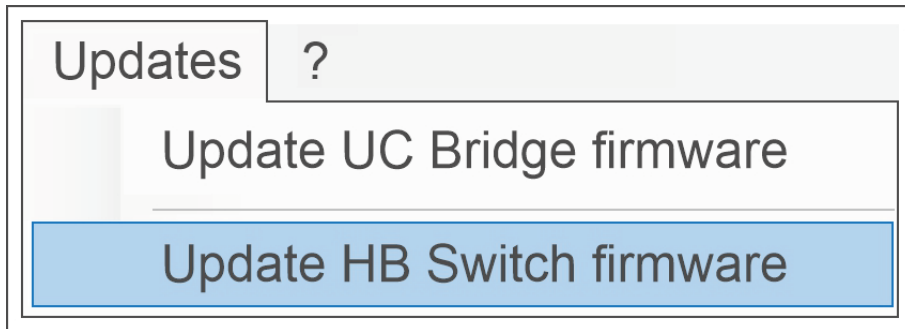

6.2.8 – Options

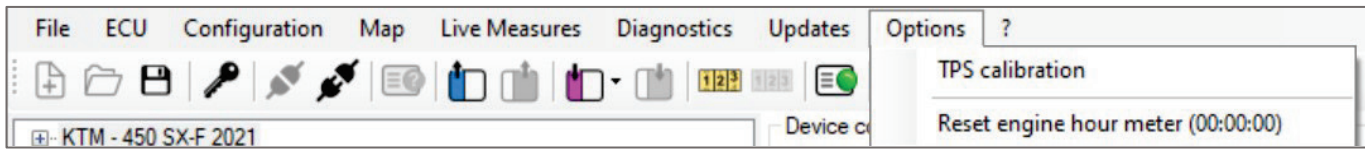

TPS Calibration: this command is used to calibrate the Throttle position sensor.

First of all, **please note that this command is only available if you are connected to the ECU and you have an open ECU project.** Clicking the TPS calibration command, the following tab will appear.

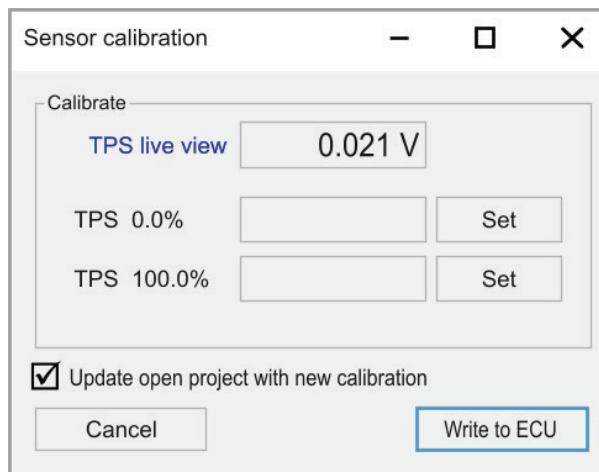

The first row shows the TPS live measure expressed in volts. To calibrate the TPS keep the throttle in its zero position (completely closed) and click "Set" in correspondence of TPS 0.0%. The value in volts, corresponding to throttle zero position, will appear as shown in the example below:

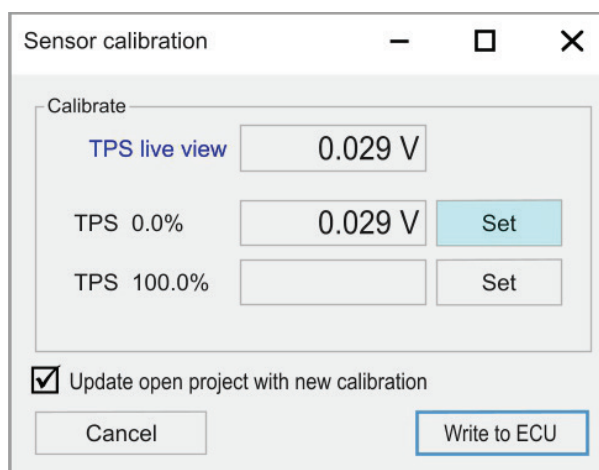

Then move the throttle in the 100% position (fully open) and click "Set" in correspondence of TPS 100.0%. The value in volts, corresponding to the throttle fully open position will appear as shown in the example below:

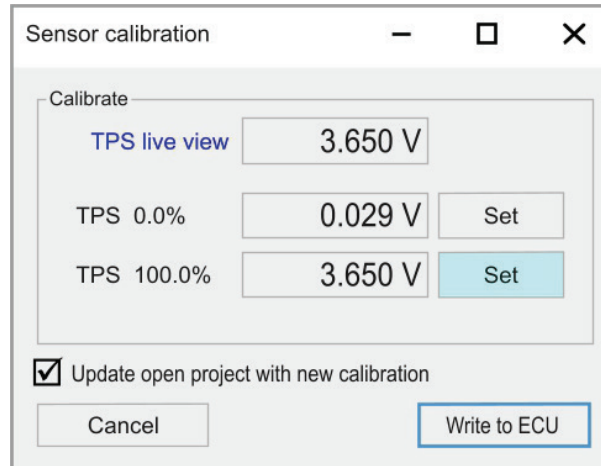

Sensor calibration		
Calibrate		
TPS live view	3.650 V	
TPS 0.0%	0.029 V	Set
TPS 100.0%	3.650 V	Set
<input checked="" type="checkbox"/> Update open project with new calibration		
Cancel		Write to ECU

Afterwards, clicking "Write to ECU", the TPS calibration is flashed into the ECU. Keep in mind that, if the checkbox "Update open project with new calibration" is marked, the TPS calibration will be updated also to the open project.

Reset engine hour meter: This command is used to reset the engine hour meter.

7 – Icon bar

This bar features some shortcut icons for the most common commands. Some of these icons are activated only if the project is open, others when the project is open and the ECU linked.



The icons are to:

	Create a New Project		Stop Live Measure
	Open Project		View diagnostic fault: no fault is detected
	Save Project		View diagnostic fault: one or more faults are detected
	Manage Project Password		Show Live Measures panel
	Link to ECU (in order to work on that specific connected ECU)		Hide Live Measures panel
	Unlink from ECU		Web update available, web connection detected
	ECU configuration info: tells the user for the bike model the ECU is configured for.		Web update ready for installation and web connection detected
	Read configuration from ECU		No web update, web connection detected
	Read running Map from ECU		Downloading web update, web connection detected
	Flash configuration to ECU		No web update, web connection not detected
	Flash running map to ECU		Web update available, web connection not detected
	Start Live Measures		Link to AiM web site

8 – Project view

The **Project** is the sum of all the 6 maps and the configuration that describe the behaviour of a bike. In this chapter we explain how to develop and modify a project.

Once an existing project has been opened or a new one created, the software shows the image below. In the Project tree view the software shows:

- Motorcycle model (GasGas – MC 250F 2021 in the image below on the right).
- Configuration.
- The six Maps.
- Expansion: the Handlebar Switch and related parameters.

The Project tree can be expanded pressing the plus symbol; each part includes several submenus that will be explored in the following chapters.

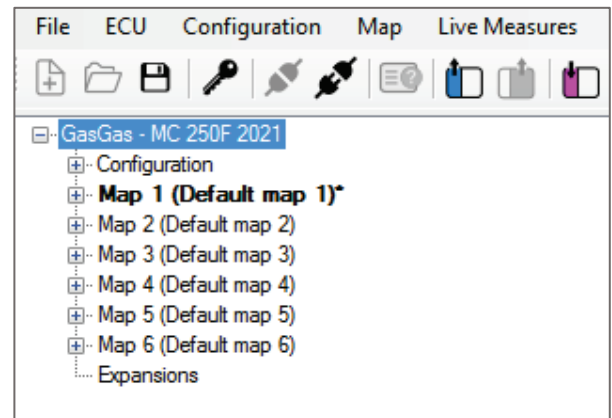

After having connected your ECU, you can find the ECU Info section:

- Motorcycle model
- Number of maps
- ECU model
- ECU Serial number
- Hardware version
- Firmware version
- Bootloader version
- Production date
- Notes
- Base project version and notes
- Type of Gasoline
- Password protection of the project

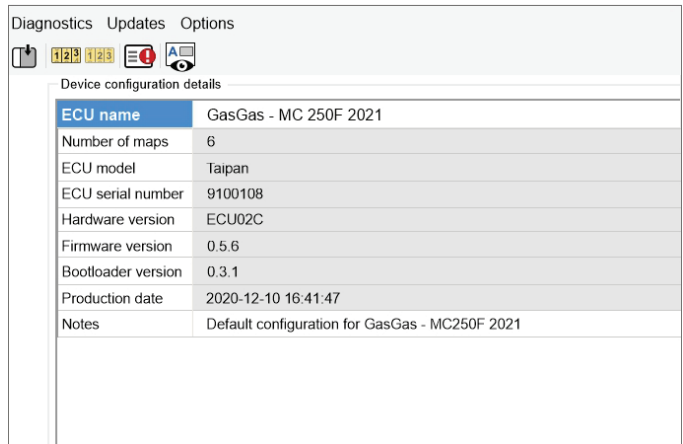

Device configuration details	
ECU name	GasGas - MC 250F 2021
Number of maps	6
ECU model	Taipan
ECU serial number	9100108
Hardware version	ECU02C
Firmware version	0.5.6
Bootloader version	0.3.1
Production date	2020-12-10 16:41:47
Notes	Default configuration for GasGas - MC250F 2021

8.1 – Configuration

The configuration section lets you manage all the parameters that are not directly related to the engine performance:

- second injector.
- sensors plausibility.
- kill switch and MIL lamp timers.
- map switch.
- parameters for launch control strategy.
- pre injection.
- RPM limiters.
- drop sensor.
- strategies for injection, injection phase, neutral and quick shift
- Vb out

These features are collected in the following three groups:

- Parameters, strategies and Vb out
- CAN configuration
- Sensors

8.1.1 – Parameters

8.1.1.1 – Motorcycle Setup

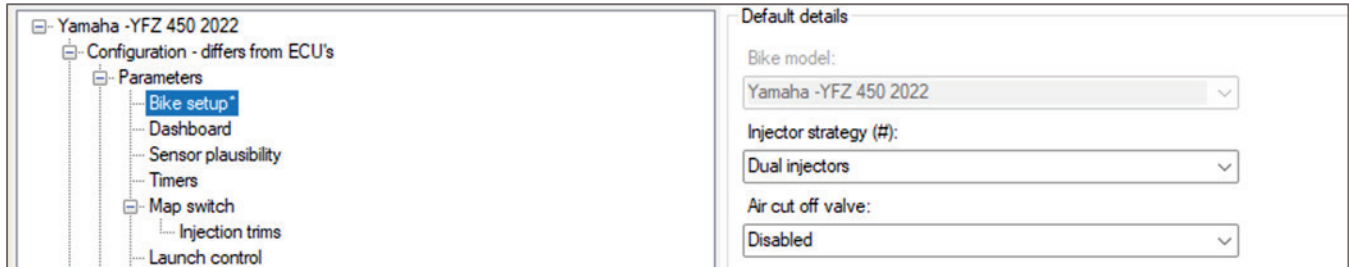

Default details

Bike model:
Yamaha -YFZ 450 2022

Injector strategy (#):
Dual injectors

Air cut off valve:
Disabled

In this section it is possible to enable the second injector if present; moreover, if you are configuring Yarara ECU you can configure the Air cut off valve to be closed if you select “Disabled” or open if you want a passage of air to exhaust. The default is closed position (Air cut off valve Disabled).

Please note: after having enabled the second injector, you must define the strategy for activating it, filling the proper injector tables located in the Map section -> Fuel -> Injector (1 and 2).

8.1.1.2 – Dashboard (Yarara only)

Configuring Yarara ECU you can choose at which temperature threshold value that turns on/off the ECT warning light on the ATV dashboard.

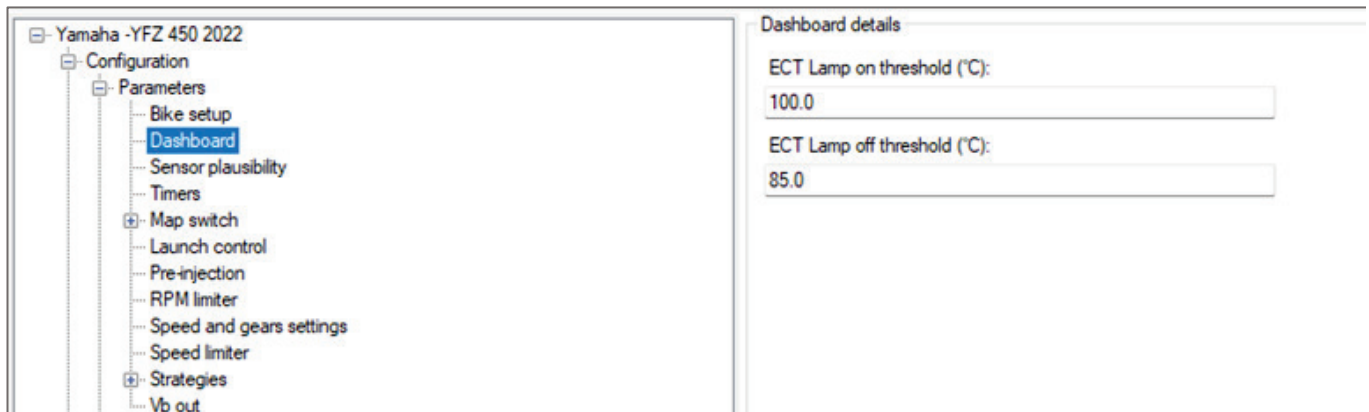

Dashboard details

ECT Lamp on threshold (°C):
100.0

ECT Lamp off threshold (°C):
85.0

8.1.1.3 – Sensor Plausibility

Here you can set the acceptability output range of each sensor connected to the ECU. When a sensor gives an output out of range, the default value is associated to the sensor:

- TPS default value: 0.
- ECT default value: 70°C.
- IAT default value: 20°C.
- MAP default value: 1.000 bar
- BARO default value: 1.013 bar

GasGas - MC 250F 2021

- [-] Configuration
 - [-] Parameters
 - Bike setup
 - Sensor plausibility**
 - Timers
 - [-] Map switch
 - Injection trims
 - Launch control
 - Pre-injection*
 - RPM limiter
 - [-] Strategies
 - Drop sensor
 - Injection strategy
 - Injectors phase strategy
 - Neutral strategy
 - Quickshift
 - Vb out
- [+] CAN configuration
- [+] Sensors
- [+] **Map 1 (Default map 1)**
- [+] Map 2 (Default map 2)
- [+] Map 3 (Default map 3)
- [+] Map 4 (Default map 4)
- [+] Map 5 (Default map 5)
- [+] Map 6 (Default map 6)
- Expansions

Sensor plausibility details

EWT sensor min plausible value (V):	<input type="text" value="0.100"/>	EWT sensor max plausible value (V):	<input type="text" value="4.600"/>
IAT sensor min plausible value (V):	<input type="text" value="0.100"/>	IAT sensor max plausible value (V):	<input type="text" value="4.600"/>
MAP sensor min plausible value (V):	<input type="text" value="0.200"/>	MAP sensor max plausible value (V):	<input type="text" value="4.000"/>
TPS sensor min plausible value (V):	<input type="text" value="0.250"/>	TPS sensor max plausible value (V):	<input type="text" value="4.800"/>
Gear sensor min plausible value (V):	<input type="text" value="0.200"/>	Gear sensor max plausible value (V):	<input type="text" value="4.000"/>
Drop sensor min plausible value (V):	<input type="text" value="0.000"/>	Drop sensor max plausible value (V):	<input type="text" value="5.000"/>
Min map switch plausible value (V):	<input type="text" value="0.000"/>	Max map switch plausible value (V):	<input type="text" value="5.000"/>
Min spare 1 plausible value (V):	<input type="text" value="0.000"/>	Max spare 1 plausible value (V):	<input type="text" value="5.000"/>
Min spare 2 plausible value (V):	<input type="text" value="0.000"/>	Max spare 2 plausible value (V):	<input type="text" value="5.000"/>

Just a few words about the **Min Map Switch range sensor**: this field is intended to define the range of the Min Map Switch and appears in the KTM/Husqvarna project only because these models only have the analogue switch input.



8.1.1.4 – Timers

<ul style="list-style-type: none">[-] GasGas - MC 250F 2021<ul style="list-style-type: none">[-] Configuration<ul style="list-style-type: none">[-] Parameters<ul style="list-style-type: none">... Bike setup... Sensor plausibilityTimers[-] Map switch<ul style="list-style-type: none">... Injection trims... Launch control	Timers details MIL test on timer (s): <input type="text" value="2.000"/> Kill switch debounce time (s): <input type="text" value="0.3"/>
--	---

Here you can set timers for MIL lamp and kill switch.

- MIL test on timer(s): time that MIL (Malfunction Indicator Lamp) is on for initial check.
- Kill switch debounce time(s): minimum time the kill switch is pressed to activate the motorcycle stop.

8.1.1.5 – Map switch

In this section you can set the configuration parameters of the Handlebar switch.

Injectors trims: in this section you can set the percentage steps, the level and the ranges of the fuel corrections that will be set by the Handlebar Switch. Setting for example all the step percentages to 5%:

- at Trim injector correction 3, there will be no correction
- at Trim injector correction 4 and 5, there will be a fuel correction of + 5% or +10%
- at Trim injector correction 2 and 1 there will be a fuel correction of -5% or -10%

Finally, the thresholds between Low and Mid RPM and between Low Mid and High RPM are set in the dedicated fields.

8.1.1.6 – Launch Control

Launch control is an electronic aid to assist riders to accelerate from a standing start.



This strategy has three different states: **ENGAGED**, **ON** and **OFF**.

ENGAGED (motorcycle ready to go but still stationary): the motorcycle needs to be in these conditions:

- launch control enabled in the running map.
- launch control requested pushing launch control button on the Handlebar Switch.
- RPM less than maximum RPM value set for launch control activation.
- bike TPS value less than the maximum TPS threshold value for launch control activation (%)
- be in neutral or first gear

Only if these conditions are true the strategy will be engaged.

When Launch control is engaged you may limit RPM value at a configurable RPM value set in the field.

Temporary RPM limiter. RPM limiter is disabled at the motorcycle starting when the RPM has a drop that you may define in the field: Engine speed gap (Rpm)

When the motorcycle starts moving Launch Control strategy turns **ON** and temporary launch control RPM limiter is activated till when an RPM drop is detected. At this point temporary launch control RPM limiter is deactivated, the normal RPM limiter comes back and the Launch Control table is used.

The Launch Control is **deactivated** in two different ways:

- Deactivate LC after a pre-defined time period – launch control deactivation time. It sets the seconds after which LC turns off
- Deactivate LC at a pre-defined gear – Launch control deactivation gear. It sets the gear that turns launch control off.

You can find the launch control tables in Map -> Launch control (injection launch control main table – ignition launch control main table).

8.1.1.7 – Pre-injection

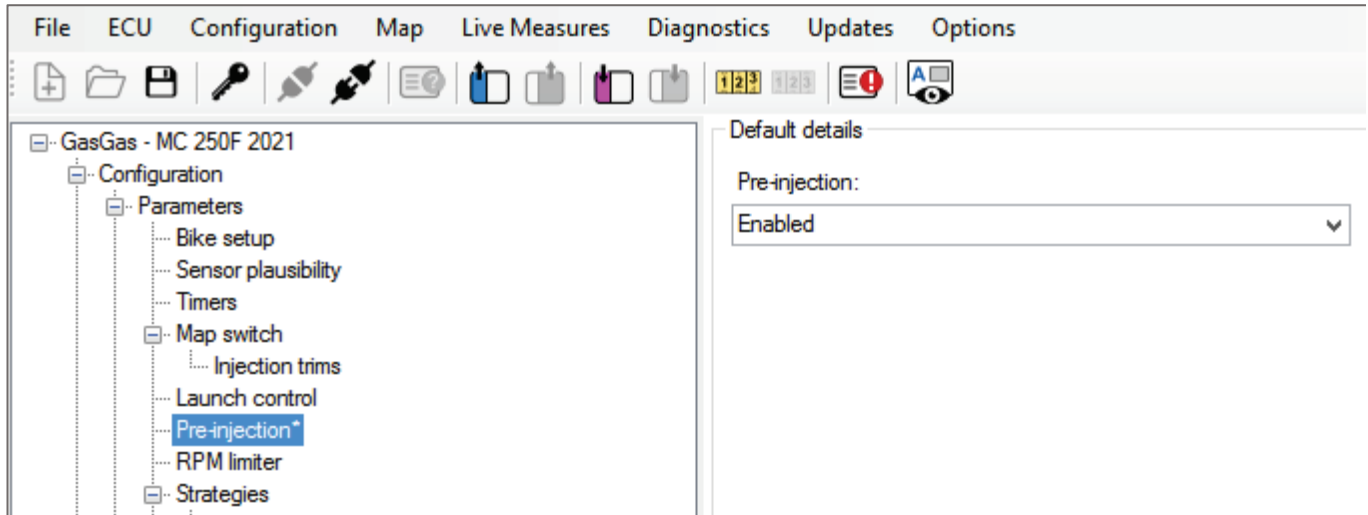

The **pre-injection** is an amount of fuel injected early at the very first crankshaft instants to clean the tubes and improving the fuel passage.

It is possible to enable the pre-injection, while you may set the quantity of injected fuel, in dependence of the water temperature, in the table at: Map chosen –> Fuel –> Pre-injection.

8.1.1.8 - RPM Limiter

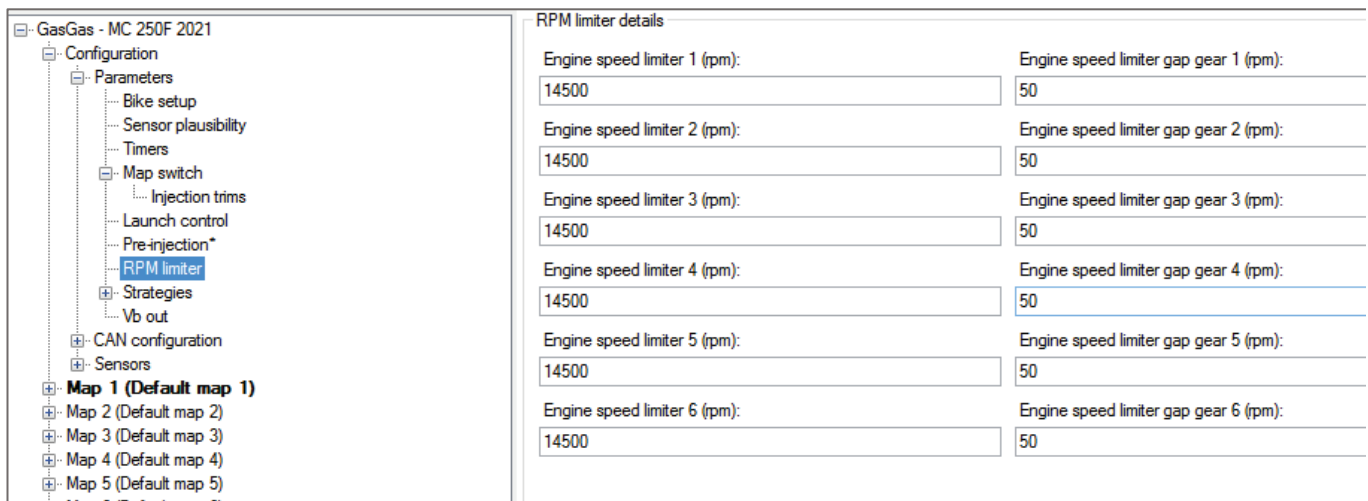

Here you may set a different RPM threshold per each map.

Beside the limiter values, you may define the RPM gap in order to define for each map the RPM value that exits limiter strategy.

8.1.1.9 – Speed and gears settings (Yarara only)

For a proper speed and gear calculation strategies working you need to add correctly the following parameters:

- Wheel circumference in mm
- Pulse per wheel revolution (number of gear teeth where the speed sensor is fitted)
- Gear ratios of all five gears

The screenshot shows a configuration window for a Yamaha-YFZ 450 2022. On the left is a tree view with 'Speed and gears settings' selected. On the right, the 'Speed and gears settings details' panel contains the following fields:

Wheel circumference (mm):	1394	Pulses per wheel revolution (#):	31
Secondary gear ratio (#):	2.714	Primary gear ratio (#):	2.652
First gear ratio (#):	2.500	Second gear ratio (#):	2.000
Third gear ratio (#):	1.632	Fourth gear ratio (#):	1.333
Fifth gear ratio (#):	1.095		

8.1.1.10 – Speed limiter

Here it is possible to configure the speed limiter parameters:

- target speed: the target speed that the motorbike must maintain till the strategy remain engaged
- speed gap: defines the range of the speed target where the pit limiter cutting strategy takes place

The screenshot shows a configuration window for a Yamaha-YFZ 450 2022. On the left is a tree view with 'Speed limiter' selected. On the right, the 'Speed limiter details' panel contains the following fields:

Speed limiter strategy enabled:	Enabled
Target speed (km/h):	120.0
Speed gap (km/h):	5.0

8.1.1.11 – Strategies

Here you can manage:

- barometric calculation
- Drop sensor
- Fan control
- Injection strategy
- Idle motor (Yarara only)
- Injection phase strategy
- Lean angle sensor (ATV only)
- neutral strategy
- Quickshaft

Barometric calculation

Here you can set an Automatic calculation of the barometric pressure or a Start-up calculation.

Using the first option the ECU will continue to update the barometric pressure value while choosing the second option the ECU will compute the Barometric Pressure only at the vehicle start-up.

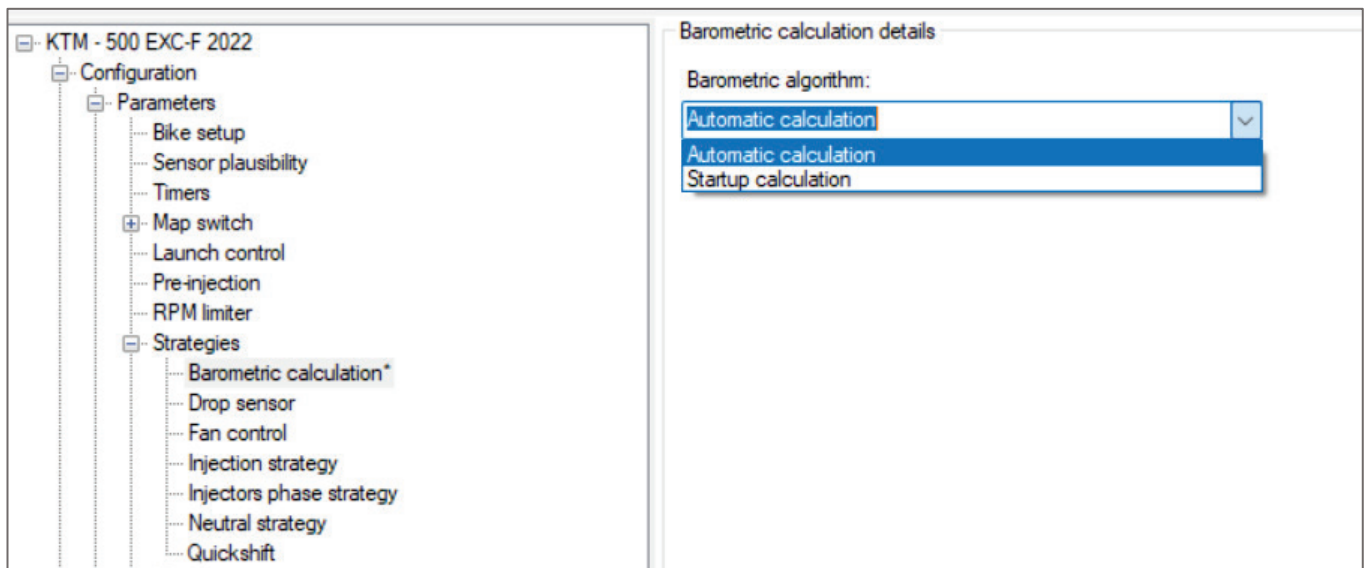

The screenshot displays the configuration software interface for a KTM 500 EXC-F 2022. On the left, a tree view shows the 'Strategies' menu expanded, with 'Barometric calculation*' selected. On the right, the 'Barometric calculation details' dialog is open, showing a dropdown menu for 'Barometric algorithm:' with 'Automatic calculation' selected.

Drop sensor

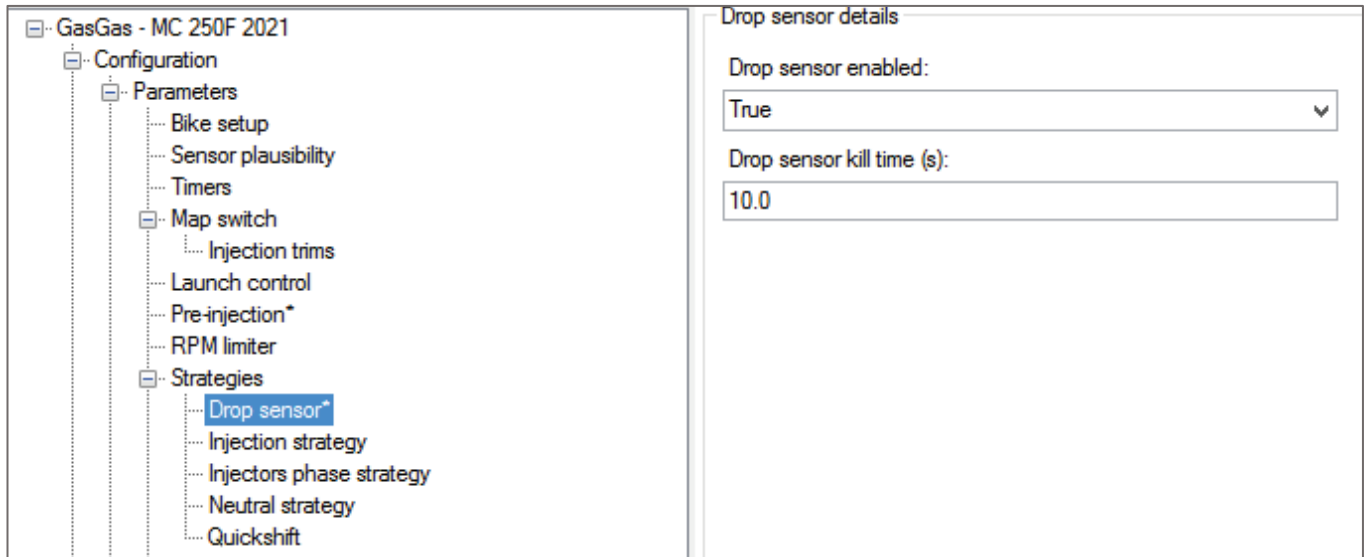

The screenshot shows a configuration window for a GasGas - MC 250F 2021. On the left is a tree view with the following structure:

- GasGas - MC 250F 2021
 - Configuration
 - Parameters
 - Bike setup
 - Sensor plausibility
 - Timers
 - Map switch
 - Injection trims
 - Launch control
 - Pre-injection*
 - RPM limiter
 - Strategies
 - Drop sensor***
 - Injection strategy
 - Injectors phase strategy
 - Neutral strategy
 - Quickshift

On the right, the 'Drop sensor details' panel contains the following settings:

- Drop sensor enabled: True (dropdown menu)
- Drop sensor kill time (s): 10.0 (text input field)

You can set the parameters for the Drop sensor, the sensor used for evaluating the bike inclination.

- Drop sensor enabled: False/True – to enable the drop sensor signal.
- Drop sensor kill time – if the drop sensor is enabled, select the time to wait before the engine is killed after the drop sensor signal has been triggered.

Please note: this sensor is not present on Honda bikes and all ATV models so in that case this section is not available.

Fan control (Enduro bikes and ATV only)

Fan control parameters are to set FAN control intervention temperature; this option is only available on Enduro bikes and ATVs.

- Start fan if engine temperature above (°C): if engine temperature exceeds this threshold the cooling fan switches on.
- Stop fan if engine temperature below(°C): with FAN control active, if and only if engine temperature drops below the fixed threshold, cooling fan switches off

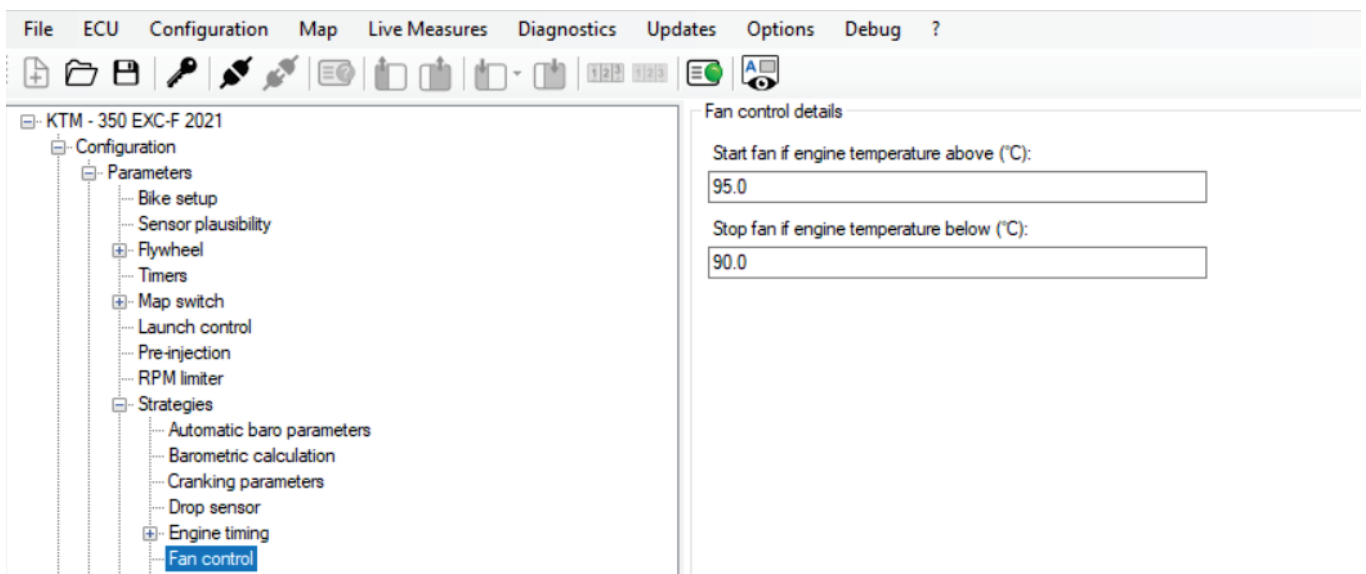

Idle motor (Yarara only)

In this section it is possible to test both manually or automatically the idle motor as shown below:

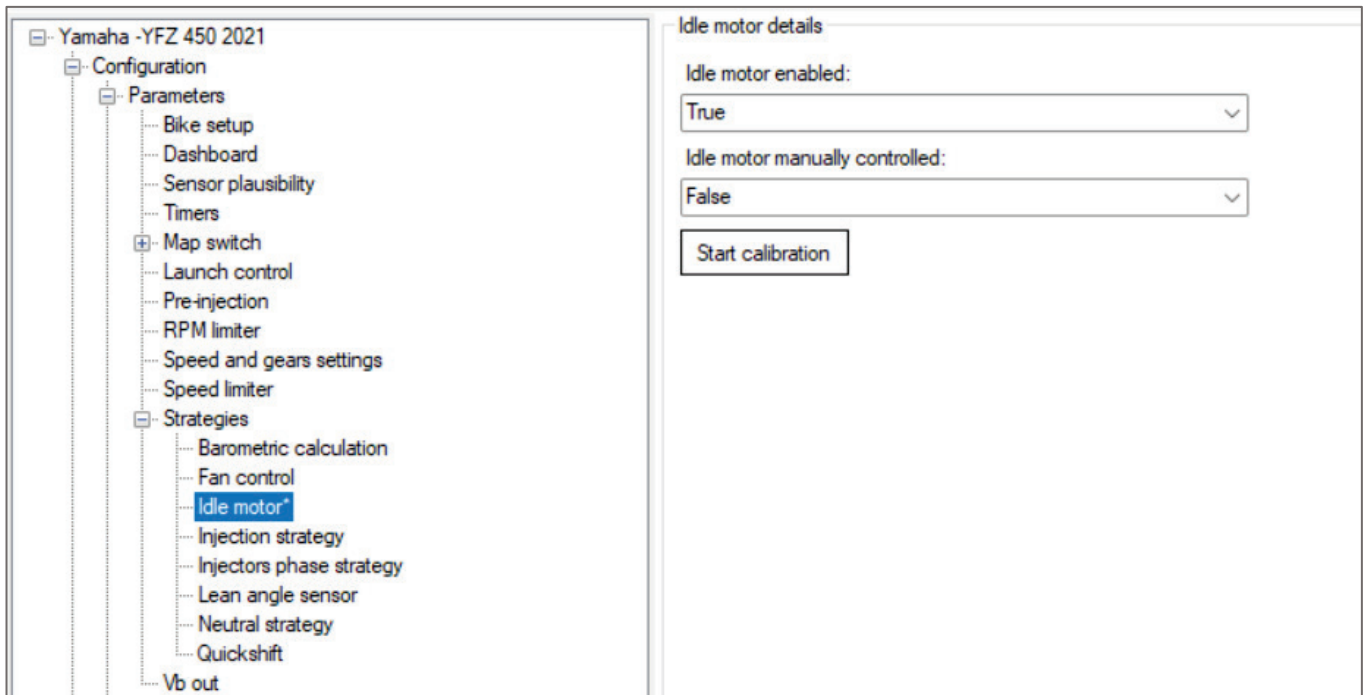

In particular, if you select to control the idle motor manually, as shown below, the following table will be available:

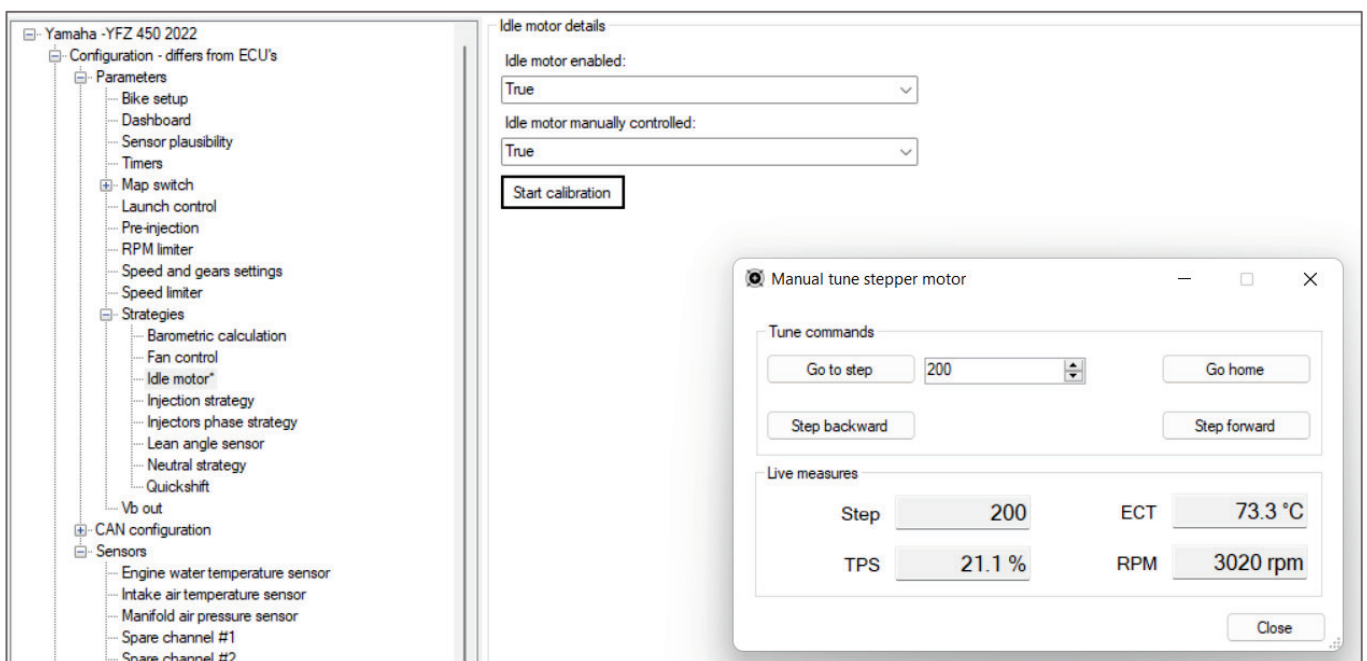

Here it is possible to select in a range between 0 and 200 steps depending on how much you want to close or open the air passage at the idle condition of the engine. Consider that if the idle motor is at step 200 it means that engine at idling is letting pass the minimum air level, instead the 0 position means that the passage of air is at the maximum position.

Control manually the idle motor could be useful if you want to find how many steps are needed in function of the cooling temperature to achieve a target engine speed.

Instead, if you want to change and test the parameters of the automatic strategy of the idle motor, first you have to select "True" in the "Idle motor Enabled" menu and "False" in the "Idle motor -> manually controlled" menu, as shown below.

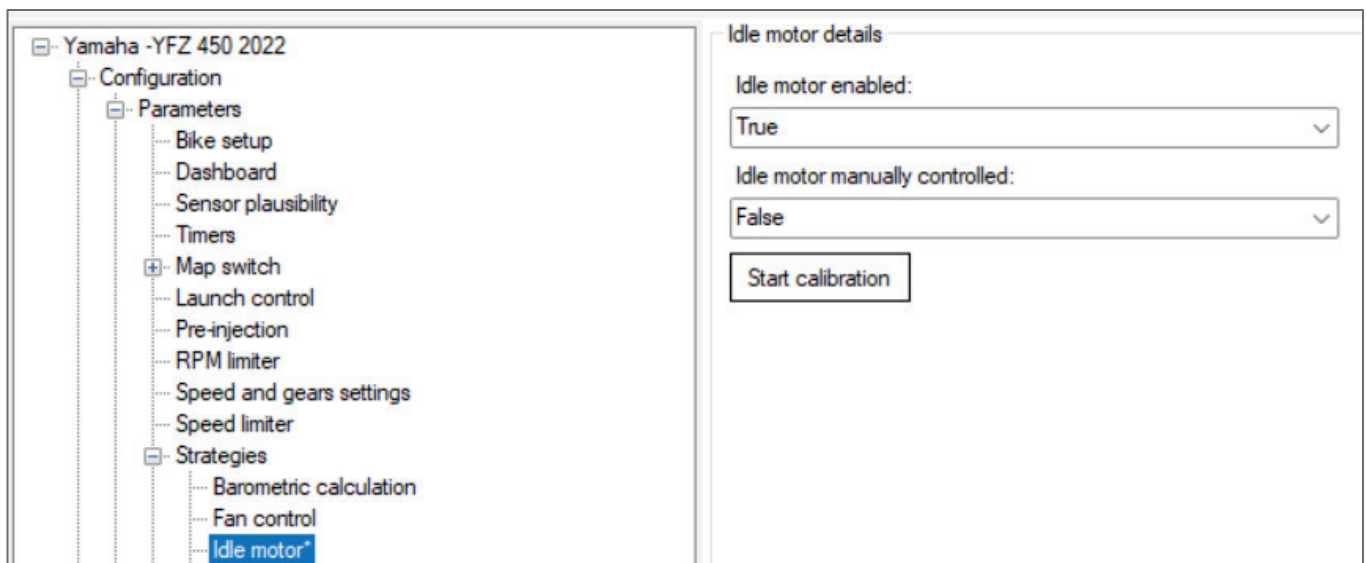

Please keep in mind that to pass from manual to automatic control it is necessary to change those settings, write the configuration back to the ECU and update the strategy change.

Then, if you press on “Start calibration” the calibration menu of this strategy will appear, as shown below:

Calibrate PID

PID setup

KP (#): Set KI (#): Set KD (#): Set

Table 2D

Configuration - Strategies.Idle motor.ISCV table (°C)

°C	-10.0	-5.0	0.0	5.0	10.0	15.0	20.0	30.0	40.0	50.0	60.0	70.0	80.0	90.0	100.0	110.0
#	0	0	0	10	20	30	30	30	40	40	40	40	40	40	40	40
rpm	2000	2000	2000	2000	2000	2000	2000	2000	2000	2000	2000	2000	2000	2000	2000	2000

X: °C (min: -200.0, max: 200.0)
Y: -
f(X, Y): -

Lock breakpoints

Reset error

Live measures

Step P term
ECT I term
TPS D term
RPM PID result
PID state

Graph: Elapsed time vs PID terms (P term, I term, D term, PID result)

OK Cancel

Progress... %

Please remember that the automatic strategy consists in two stages of operation; one being an open loop strategy and the other being a PID closed loop strategy.



There is a table with 16 breakpoints and 3 rows where it is possible to set a target engine idle level, a cooling temperature and a number of steps of the idle motor.

The first consists of a table where you can configure the target engine RPM at idling, the water temperature ECT and the steps that the idle motor does according to the water temperature.

The strategy is designed to make sure that the correct amount of air passes at each engine temperature, the default parameters that we recommend for the Yamaha YFZ 450 2022 are the following:

Table 2D 3D

Configuration - Strategies.Idle motor.ISCV table (°C)

°C	-10.0	-5.0	0.0	5.0	10.0	15.0	20.0	30.0	40.0	50.0	60.0	70.0	80.0	90.0	100.0	110.0
#	0	0	0	10	20	30	30	30	30	40	40	40	40	40	40	40
rpm	2000	2000	2000	2000	2000	2000	2000	2000	2000	2000	2000	2000	2000	2000	2000	2000

X: °C (min: -200.0, max: 200.0)
Y: -
f(X, Y): -

Lock breakpoints

Moreover, when the TPS is under 3% and the engine speed is comprised in a certain range, the engine is considered idling and so the closed loop strategy is applied, outside this ranges (engine speed outside the range and/or TPS higher than 3%), the open loop strategy is applied.

At this point the PID automatically adjusts the steps of the idle motor in order to bring the engine revolutions to the idle target (in this case 2000 rpm). It is possible to adapt the PID control to your needs by tune up the 3 PID constants KP, KI, KD.

You can change the PID constants and flash them to the ECU using the set button next to the parameters, then in live measure you can see how the PID controller behaves.

Please note that, at cranking time, the idle motor is letting pass the maximum amount of air and then after the engine is running, the idle motor is managed by the two strategies. Remember also that when the ATV key switch is turned off (even if the engine is not running) or when the engine is turned off unintentionally (not switched off by key switch), the ECU will perform the idle motor calibration (coming home strategies) opening the passage of air for the next cranking time.

Injection strategy

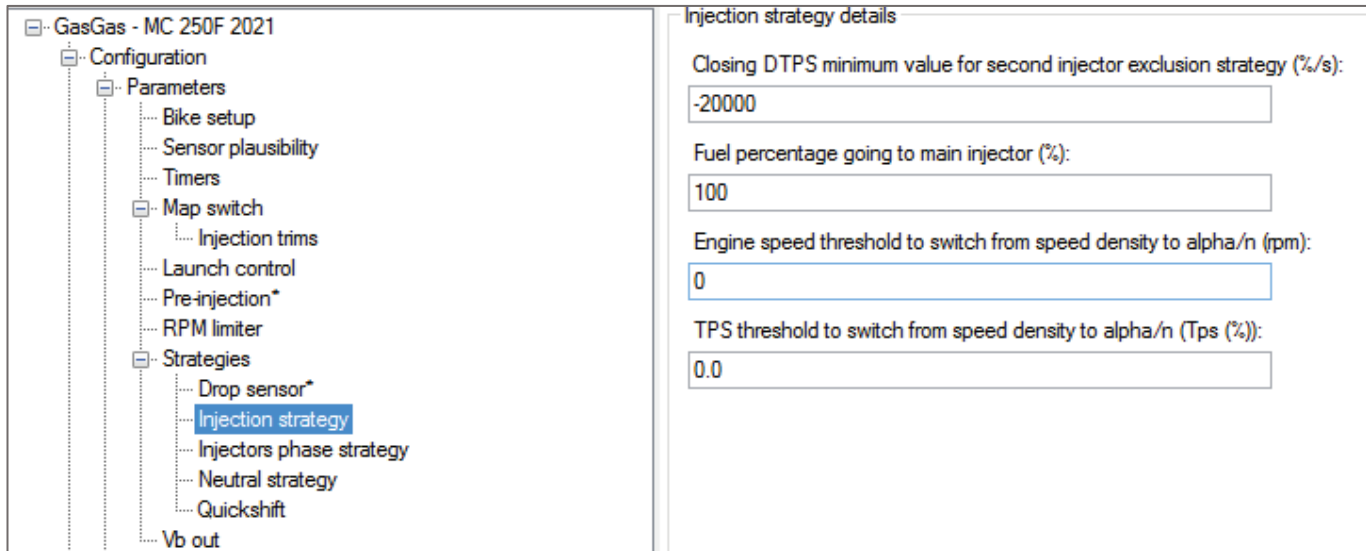

In this section is explained how to manage the second injector during a rapid throttle closure. The second injector is generally positioned above the throttle in order to have a better air/fuel mixture at high RPM /throttle range. After a rapid throttle closure, a quantity of fuel may remain nearby the throttle valve and, at the next throttle rapid opening, may produce a very fat mixture inside the cylinder. To avoid this problem with AiM ECUs you can set the fuel percentage that passes through the main injector after a fast TPS closing, helping to keep the fuel/air ratio optimal even in this situation.

The parameters to be set are:

- **Closing DTSPS** (TPS closing speed) injector exclusion strategy (%/s): TPS closing speed per second over which to start the strategy.
- **Fuel percentage going to main injector** (%) when the previous condition related to the closure of the DTSPS is respected.

To set up **injector 1** fuel values go to: map → fuel → injector 1 (injector 1 battery corrections – injector 1 phase)
 To set up **injector 2** fuel values go to: map → fuel → injector 2 (injector 2 battery corrections – injector 2 percentage – injector 2 phase).

The next two parameters that define the Injection Strategy are intended to decide which table is to be used for establishing the amount of gasoline to be injected. There are two different ways for calculating the amount of gasoline used in each active phase:

- In dependence upon the amount of aspired air, Speed – density, calculated from MAP sensor and RPM.
- In dependence upon the throttle angle (alpha) and RPM.

The first method gives a more precise idea of the oxygen available for the combustion, so let us calculate the amount of gasoline necessary to get the desired lambda value but may be used only when RPM value is low and TPS is partially open. Over an RPM threshold and a TPS threshold, that you may define here, it is better to use the second method; so, when RPM and TPS are under the set thresholds, the Speed Density/RPM map is used, else the Throttle angle (alpha) / RPM map is used. The parameters to be set here are:

- RPM threshold to switch from speed density to alpha/n table (RPM)
- TPS threshold to switch from speed density to alpha/n table (%)

Injectors phase strategy

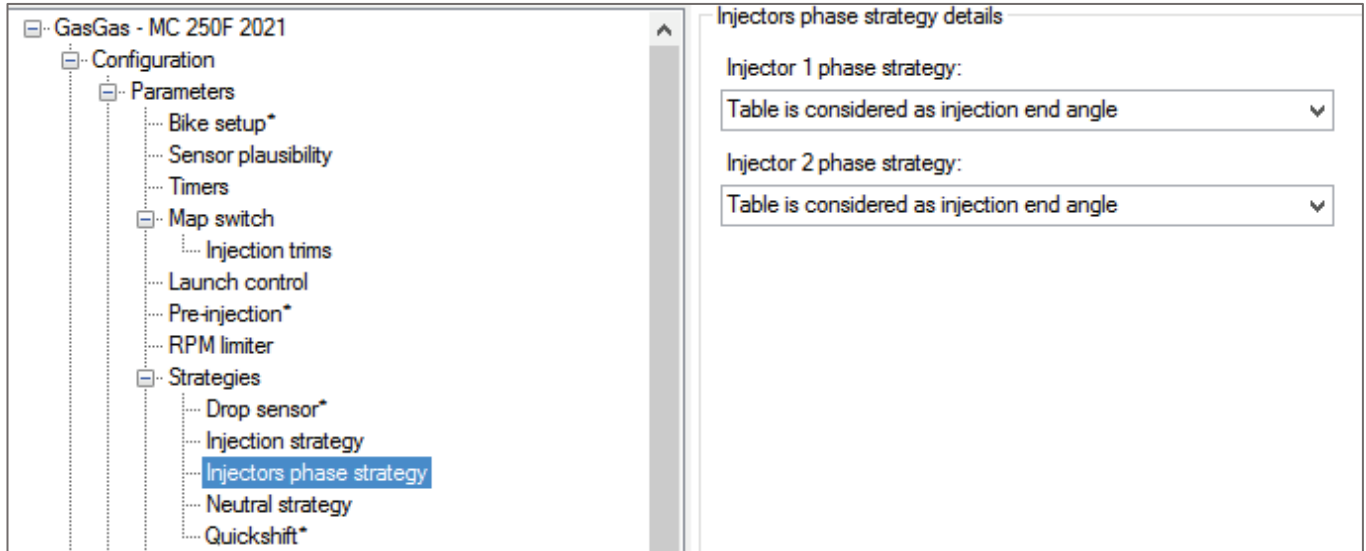

The screenshot displays the configuration interface for the 'Injectors phase strategy'. On the left, a tree view shows the hierarchy: GasGas - MC 250F 2021 > Configuration > Parameters > Map switch > Injection trims > Launch control > Pre-injection* > RPM limiter > Strategies > Injectors phase strategy (highlighted). On the right, the 'Injectors phase strategy details' panel shows two dropdown menus: 'Injector 1 phase strategy:' and 'Injector 2 phase strategy:', both set to 'Table is considered as injection end angle'.

For each injector is possible to set the injection phase as:

- the start of injection or
- the end of injection.

Lean angle sensor (ATV only)

You can set the parameters for the lean angle sensor, the sensor used for evaluating the ATV inclination.

- lean angle sensor enabled: False/True – to enable the lean angle signal.
- lean angle sensor kill time – If the lean angle sensor is enabled, select the time to wait before the engine is killed after the lean angle sensor signal has been triggered.

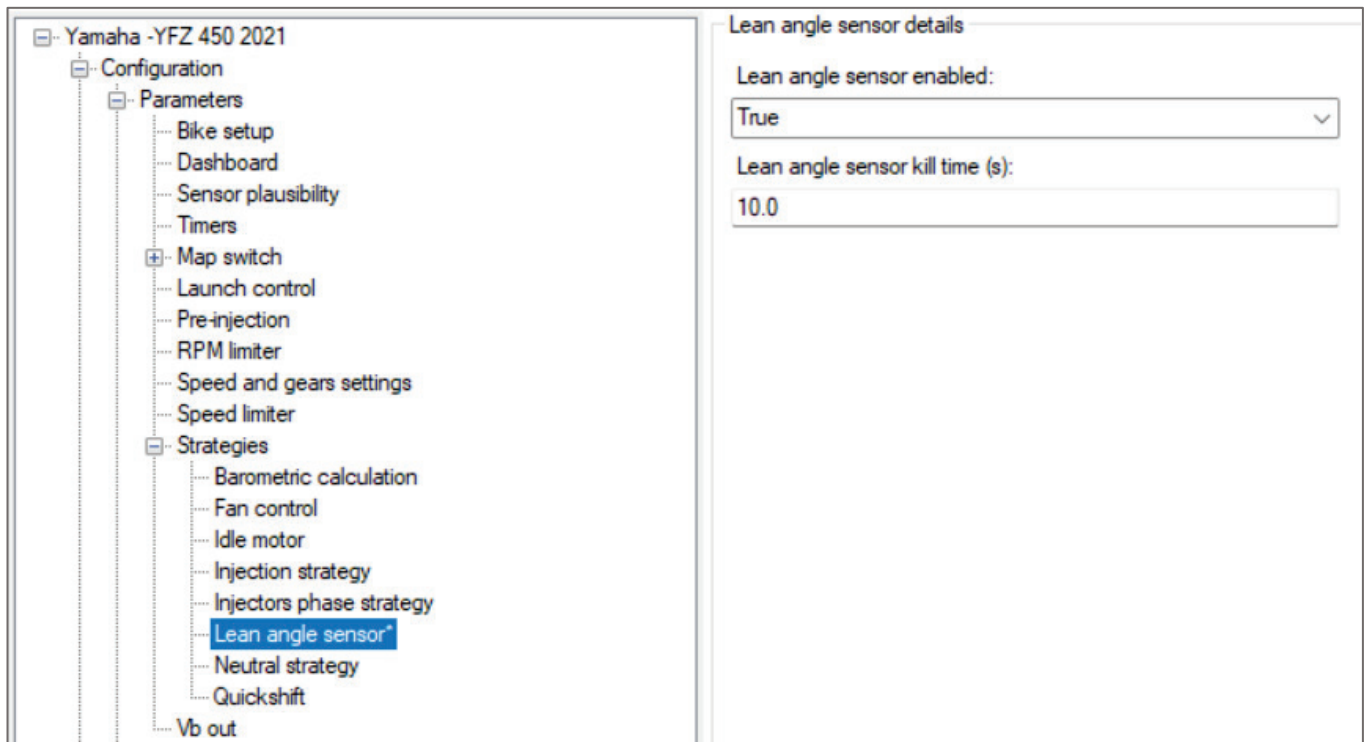

The screenshot displays the configuration interface for a Yamaha YFZ 450 2021. On the left, a tree view shows the configuration structure under 'Configuration' > 'Parameters'. The 'Lean angle sensor' option is highlighted in blue. On the right, the 'Lean angle sensor details' panel shows two settings: 'Lean angle sensor enabled' is set to 'True' (via a dropdown menu), and 'Lean angle sensor kill time (s)' is set to '10.0' (via a text input field).

Please note: at present this sensor can only be configured on Yarara ECU.

Neutral strategy

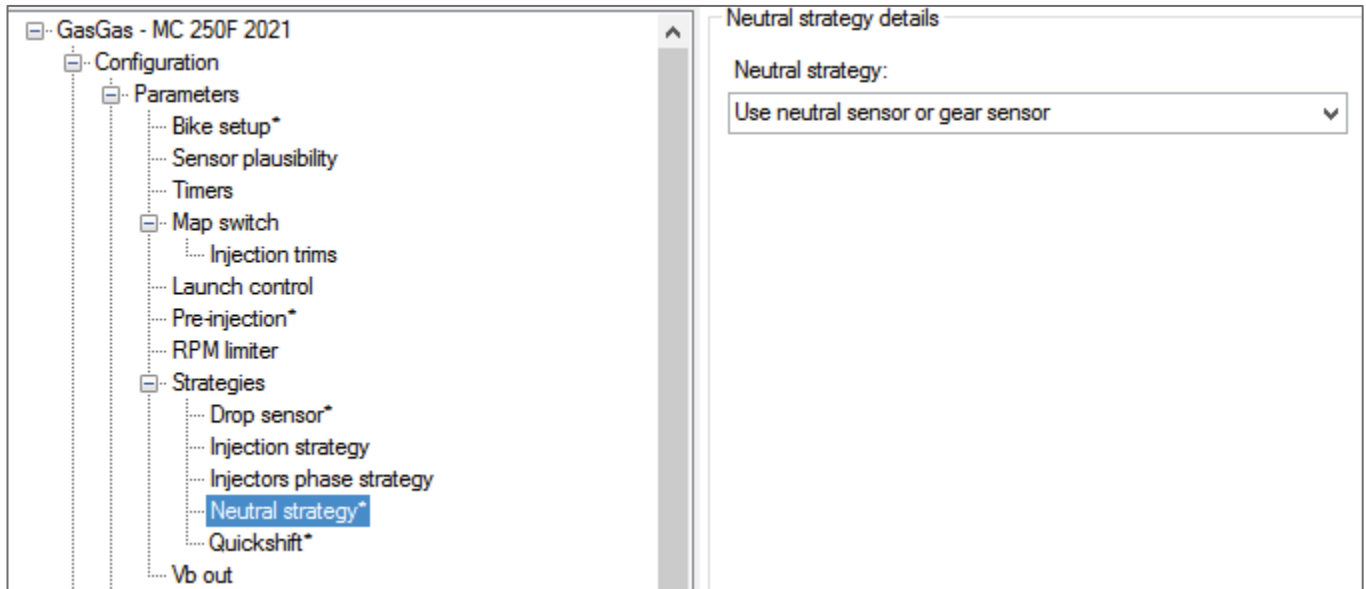

By default Map number 6 is dedicated to neutral strategy. You can choose how to engage this map in different ways:

- Strategy OFF: the strategy is disabled
- Use neutral sensor or gear sensor: if the motorcycle has a neutral or gear sensor and the neutral is detectable, once neutral is engaged the map is automatically changed to map 6, otherwise is changed to the previous default map.
- Use external switch: in this case a bi-stable switch can be plugged in, only once the switch is active the map is changed to map 6.

Quick shift

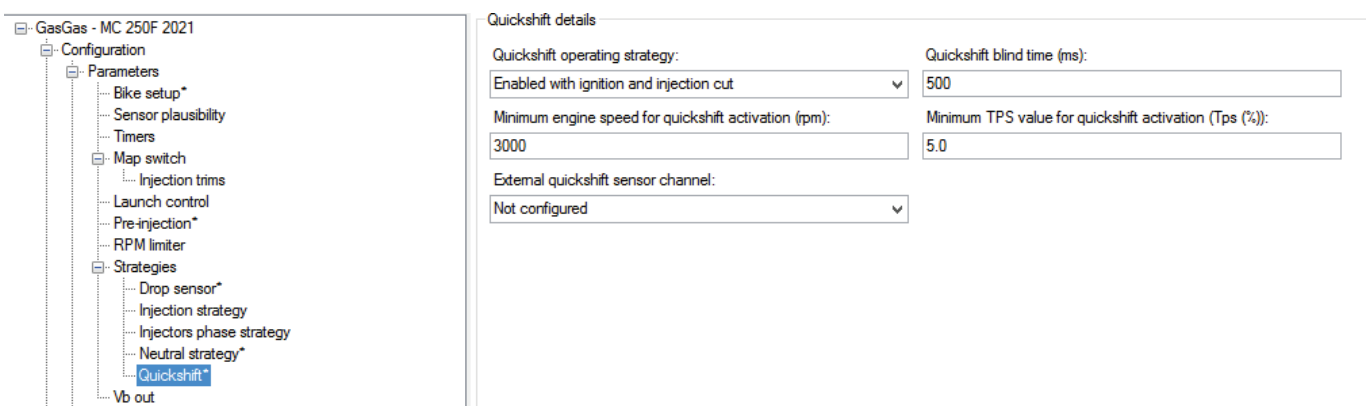

It is possible to set-up the quick shift strategy, in order to reduce the time of power loss between gear changes. This setting works in combination with a proper quick shift table, to be defined in every map (map -> quick shift)

The Quick Shift may be:

- Quick shift DISABLED
- Quick shift ENABLED with ignition cut only

- Quick shift ENABLED with injection cut only
- Quick shift ENABLED with ignition and injection cut

If Quick Shift strategy is ENABLED, you must set these parameters:

- Minimum RPM for quick shift activation.
- Minimum TPS value for quick shift activation (%)

Only if TPS and RPM are greater than the thresholds this strategy is active.

- Quick shift blind time (msec): Once the strategy is active for the calculated time from the dedicated table, another shift activation is inhibited for this blind time.
- External quick shift sensor channel: in case your bike must have an external switch, used to read the shift status, connected to one of the two spare inputs of the AiM ECUs ECU.

8.1.1.12- Vb out

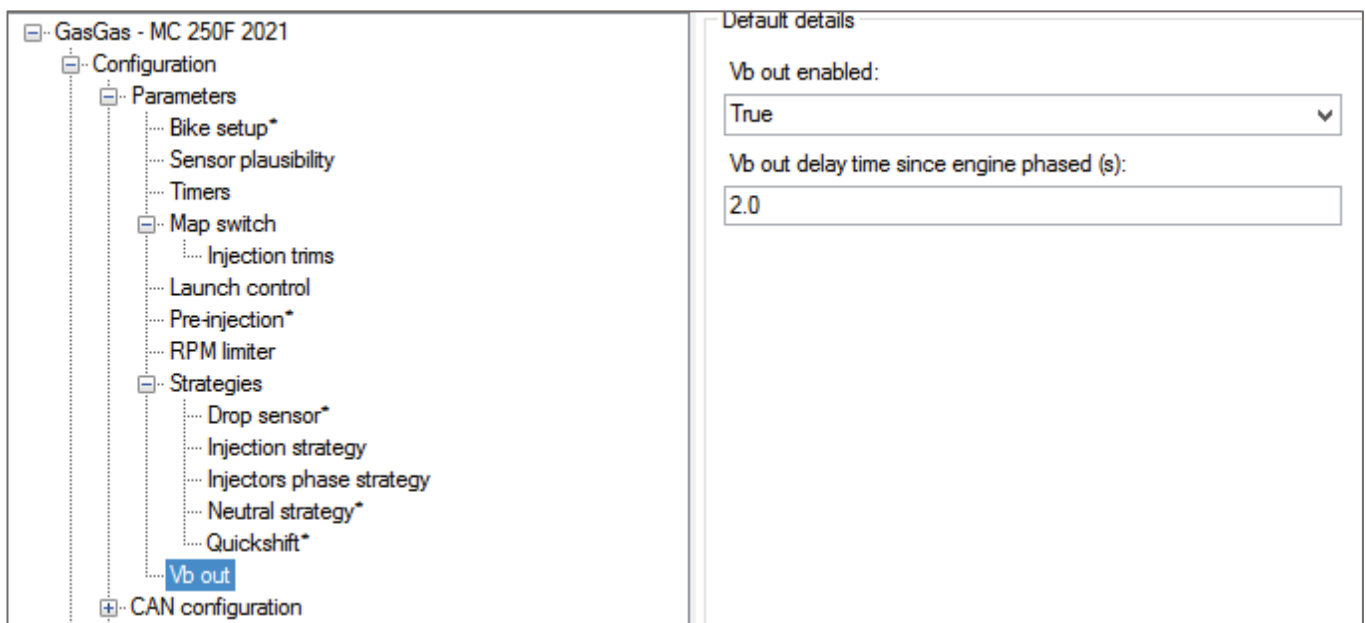

The screenshot displays the configuration interface for a GasGas MC 250F 2021. On the left, a tree view shows the configuration structure under 'Configuration' > 'Parameters'. The 'Vb out' parameter is highlighted in blue. On the right, the 'Default details' panel shows the following settings:

- Vb out enabled: True (selected in a dropdown menu)
- Vb out delay time since engine phased (s): 2.0 (entered in a text field)

AiM ECUs ECU can be enabled to generate the Vb (12V power supply) in order to power an external device (i.e., datalogger).

- Vb out enabled: False/True.
- Vb out delay time(s) - the Vb out is generated only if the engine is running and is phased. If these conditions are met, once the delay time expires the ECU starts supplying power externally.

8.1.2 – CAN Configuration

8.1.2.1 – CAN parameters

The screenshot displays the software interface for CAN configuration. On the left, a tree view shows the project structure for 'GasGas - MC 250F 2021'. The 'CAN configuration' folder is expanded, and 'CAN parameters' is selected. The right pane, titled 'CAN parameters details', shows a dropdown menu for 'Aux CAN enabled:' with the value 'AUX CAN enabled' selected.

This section is activated when the Expansions section (the last section of the project tree) is set to true. If the section is set to false, you can choose to have a CAN output or not (aux Can enabled / disabled)

8.1.3 – Sensors

In this section it is possible to define the linearisation of the analog sensors shown below or configure the spare channels to possibly connect, for instance, a quick shift sensor, a Pit limiter, an electric water pump.

The screenshot shows a list of sensors under the 'Sensors' folder. The list includes:

- Engine water temperature sensor
- Gear sensor
- Intake air temperature sensor
- Manifold air pressure sensor
- Spare channel #1
- Spare channel #2
- Throttle position sensor

8.1.3.1 – Spare channel #1 and #2

AiM ECUs offer the possibility to manage two spare sensors. Each of them may be enabled and configured, thanks to a dedicated table with 16 breakpoints. For each entry, the voltage and the corresponding sensor's measure must be defined.

8.2 – Maps

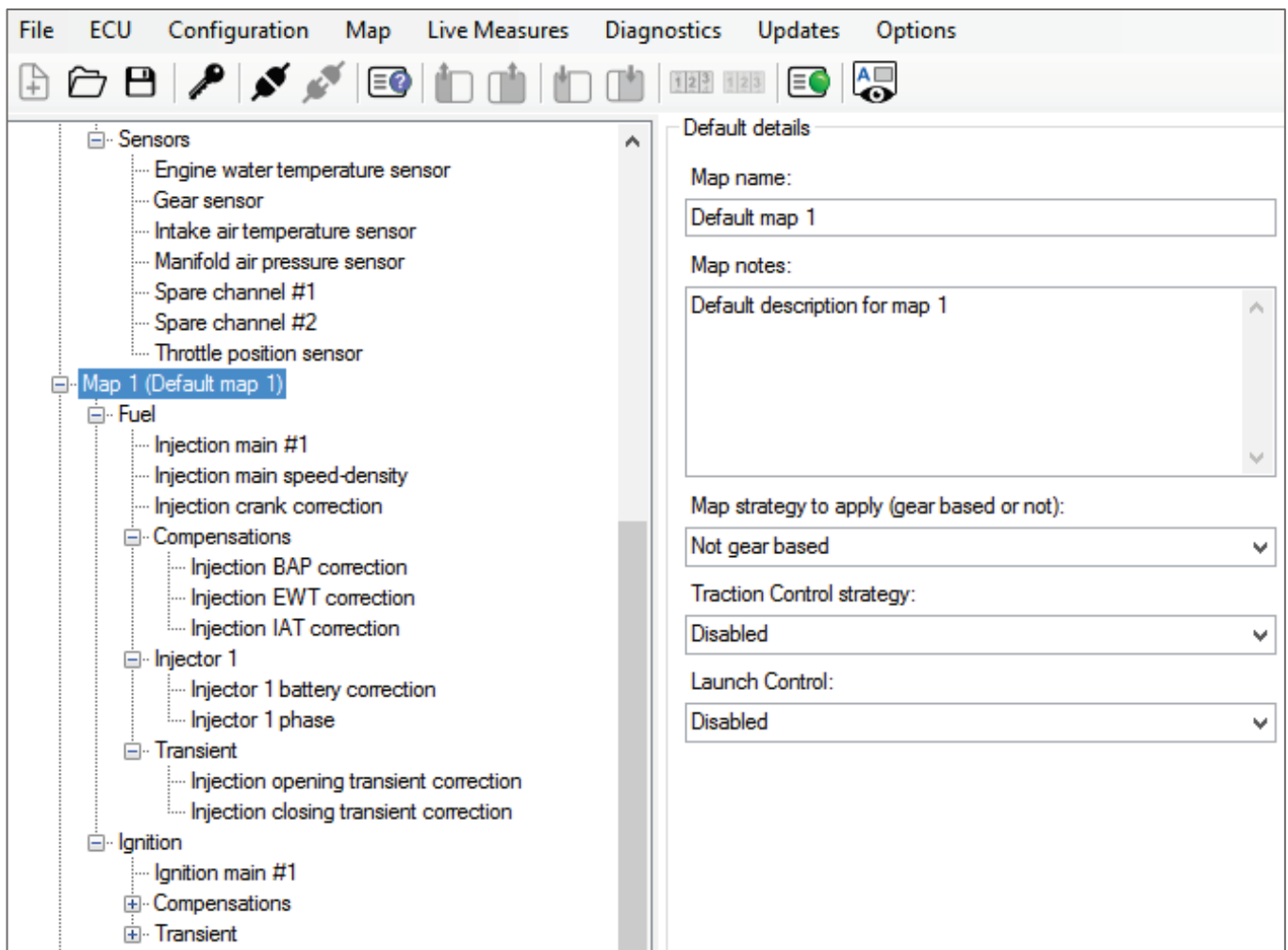

This is the section where the six ECU maps and strategies are defined. Please select a map from the Tree View and look at its details and strategies in the Data View window.

Please note: in this chapter the maps and their meanings are introduced. In Chapter 9 how to manage the entry points will be explained.

Map strategy to apply; the Map Strategy may be:

- Gear based
- Not Gear based.

In the first case, there is a different main table for injection and ignition for each gear.

Traction Control Strategy: in case Traction Control is ENABLED for each map and ECU has dedicated parameters that will be described later in this manual.

Launch Control: if Launch Control is ENABLED, for every map, the ECU has a dedicated launch control main table.

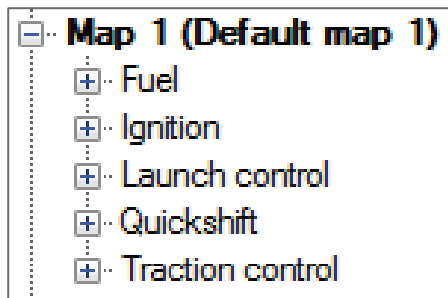

For each map you need to set the following tables:

- Fuel
- Ignition
- Launch control (if enabled)
- Quick shift (if enabled)
- Traction control (if enabled)

8.2.1 – Fuel

8.2.1.1 – Injection main #1

		Map 1 - Fuel.Injection main #1 (ms)																						
		250	500	750	1000	1250	1500	1750	2000	2250	2500	2750	3000	3250	3500	3750	4000	4250	4500	4750	5000	5250	5500	5750
0.0	0.760	0.760	0.760	0.760	0.760	0.760	0.760	0.760	0.760	0.760	0.760	0.760	0.760	0.760	0.760	0.770	0.740	0.640	0.610	0.560	0.500	0.450	0.420	0.420
2.5	1.180	1.180	1.180	1.180	1.180	1.180	1.180	1.062	1.053	1.044	1.071	1.062	1.053	0.999	0.963	0.945	0.909	0.872	0.828	0.761	0.709	0.655	0.615	0.615
5.0	1.380	1.380	1.380	1.380	1.380	1.380	1.380	1.242	1.233	1.233	1.242	1.242	1.224	1.197	1.179	1.159	1.113	1.069	1.014	0.978	0.922	0.877	0.832	0.832
10.0	1.840	1.840	1.840	1.840	1.840	1.840	1.840	1.840	1.860	1.940	1.970	1.930	1.850	1.720	1.640	1.550	1.490	1.440	1.410	1.380	1.360	1.330	1.290	1.290
25.0	3.020	3.020	3.020	3.020	3.020	3.020	3.010	2.990	3.020	3.210	3.350	3.360	3.180	2.960	2.810	2.700	2.630	2.580	2.530	2.490	2.450	2.380	2.350	2.350
33.0	3.510	3.510	3.510	3.510	3.510	3.510	3.480	3.440	3.470	3.560	3.570	3.610	3.490	3.120	3.030	2.990	2.950	2.910	2.900	2.890	2.890	2.880	2.900	2.900
50.0	3.660	3.660	3.660	3.660	3.660	3.660	3.620	3.580	3.620	3.760	3.790	3.840	3.610	3.260	3.090	3.060	3.050	3.030	3.070	3.120	3.220	3.330	3.450	3.450
66.0	3.750	3.750	3.750	3.750	3.750	3.750	3.710	3.670	3.720	3.880	4.000	3.970	3.670	3.350	3.150	3.100	3.100	3.110	3.130	3.150	3.270	3.390	3.530	3.530
75.0	3.650	3.650	3.650	3.650	3.570	3.460	3.420	3.380	3.430	3.570	3.640	3.610	3.340	3.180	3.010	2.930	2.930	2.930	2.980	3.020	3.150	3.270	3.400	3.400
100.0	3.570	3.570	3.570	3.570	3.380	3.260	3.230	3.150	3.230	3.380	3.410	3.390	3.210	3.010	2.860	2.720	2.700	2.680	2.680	2.700	2.860	3.030	3.030	3.030

- X axis: RPM – 64 breakpoints
- Y axis: TPS (%) – 10 breakpoints
- Entry points: Injection Time (ms)

This map defines the injection time, in ms, in dependence upon the RPM and Throttle position.

In case of gear dependant setting, this table is applied only to the first gear otherwise is applied to all gears. The map can also be managed with a 2D view providing a quicker overview of the calibration. In case the Map Strategy is Gear based, you may also fill the same maps for the other gears.

8.2.1.2 – Fuel injection user compensation table

From Spark 1.1.8 onwards there is also the possibility with both user and tuner license to correct the injection/ignition base maps.

More into details, below each map there are two user compensation tables as shown in the figure below:

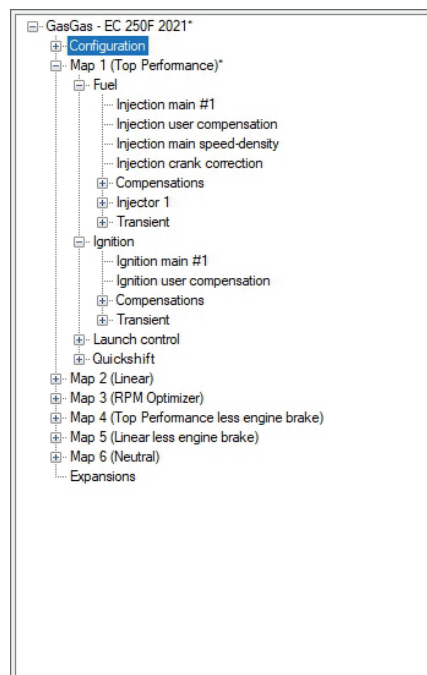



- **Injection user compensation:**

The fuel injection user compensation is a correction table where you can correct the injection time in percentage for each map, an example of an empty table is shown below. The correction range available is between +20% and -10%.

This means that if you are adding a + 10% in a point of this table the main injection map is corrected in that exact point by a 10% more of injection time.

Table 2D 3D

Map 1 - Fuel Injection user compensation (%)

Tps (%) \ rpm	1000	2000	3000	4000	5000	6000	7000	8000	9000	10000	11000	12000	13000	14000	15000	16000
10.0	0.0	0.0	0.0	0.0	0.0	0.0	0.0	0.0	0.0	0.0	0.0	0.0	0.0	0.0	0.0	0.0
20.0	0.0	0.0	0.0	0.0	0.0	0.0	0.0	0.0	0.0	0.0	0.0	0.0	0.0	0.0	0.0	0.0
30.0	0.0	0.0	0.0	0.0	0.0	0.0	0.0	0.0	0.0	0.0	0.0	0.0	0.0	0.0	0.0	0.0
40.0	0.0	0.0	0.0	0.0	0.0	0.0	0.0	0.0	0.0	0.0	0.0	0.0	0.0	0.0	0.0	0.0
50.0	0.0	0.0	0.0	0.0	0.0	0.0	0.0	0.0	0.0	0.0	0.0	0.0	0.0	0.0	0.0	0.0
60.0	0.0	0.0	0.0	0.0	0.0	0.0	0.0	0.0	0.0	0.0	0.0	0.0	0.0	0.0	0.0	0.0
70.0	0.0	0.0	0.0	0.0	0.0	0.0	0.0	0.0	0.0	0.0	0.0	0.0	0.0	0.0	0.0	0.0
80.0	0.0	0.0	0.0	0.0	0.0	0.0	0.0	0.0	0.0	0.0	0.0	0.0	0.0	0.0	0.0	0.0
90.0	0.0	0.0	0.0	0.0	0.0	0.0	0.0	0.0	0.0	0.0	0.0	0.0	0.0	0.0	0.0	0.0
100.0	0.0	0.0	0.0	0.0	0.0	0.0	0.0	0.0	0.0	0.0	0.0	0.0	0.0	0.0	0.0	0.0

X: rpm (min: 0, max: 20000)
Y: Tps (%) (min: 0.0, max: 100.0)
f(X, Y): % (min: -10.0, max: 20.0)

Lock breakpoints

Please remember that, to apply the changes made to the user compensation tables you need to connect the UC-bridge between the PC and the ECU and write the previously modified map using the command "Write ECU" or using the shortcut ALT+MAIUSC+E.

8.2.1.3 – Injection main speed-density (ms)

- Injection trims
- Launch control
- Pre-injection*
- RPM limiter
- Strategies
 - Drop sensor*
 - Injection strategy
 - Injectors phase strategy
 - Neutral strategy*
 - Quickshift*
- Vb out
- CAN configuration
- CAN parameters
- Sensors
 - Engine water temperature sensor
 - Gear sensor
 - Intake air temperature sensor
 - Manifold air pressure sensor
 - Spare channel #1
 - Spare channel #2
 - Throttle position sensor
- Map 1 (Default map 1)
 - Fuel
 - Injection main #1
 - Injection main speed-density
 - Injection crank correction

Table 2D 3D

Map 1 - Fuel.Injection main speed-density (ms)

kPa/vrpm	250	500	750	1000	1250	1500	1750	2000	2250	2500	2750	3000	3250	3500	3750	4000	4250	4500	4750	5000	5250	5500	5750
49.0	0.000	0.000	0.000	0.000	0.000	0.000	0.000	0.000	0.000	0.000	0.000	0.000	0.000	0.000	0.000	0.000	0.000	0.000	0.000	0.000	0.000	0.000	0.000
54.4	0.000	0.000	0.000	0.000	0.000	0.000	0.000	0.000	0.000	0.000	0.000	0.000	0.000	0.000	0.000	0.000	0.000	0.000	0.000	0.000	0.000	0.000	0.000
59.8	0.000	0.000	0.000	0.000	0.000	0.000	0.000	0.000	0.000	0.000	0.000	0.000	0.000	0.000	0.000	0.000	0.000	0.000	0.000	0.000	0.000	0.000	0.000
65.2	0.000	0.000	0.000	0.000	0.000	0.000	0.000	0.000	0.000	0.000	0.000	0.000	0.000	0.000	0.000	0.000	0.000	0.000	0.000	0.000	0.000	0.000	0.000
70.6	0.000	0.000	0.000	0.000	0.000	0.000	0.000	0.000	0.000	0.000	0.000	0.000	0.000	0.000	0.000	0.000	0.000	0.000	0.000	0.000	0.000	0.000	0.000
76.0	0.000	0.000	0.000	0.000	0.000	0.000	0.000	0.000	0.000	0.000	0.000	0.000	0.000	0.000	0.000	0.000	0.000	0.000	0.000	0.000	0.000	0.000	0.000
81.4	0.000	0.000	0.000	0.000	0.000	0.000	0.000	0.000	0.000	0.000	0.000	0.000	0.000	0.000	0.000	0.000	0.000	0.000	0.000	0.000	0.000	0.000	0.000
86.8	0.000	0.000	0.000	0.000	0.000	0.000	0.000	0.000	0.000	0.000	0.000	0.000	0.000	0.000	0.000	0.000	0.000	0.000	0.000	0.000	0.000	0.000	0.000
92.2	0.000	0.000	0.000	0.000	0.000	0.000	0.000	0.000	0.000	0.000	0.000	0.000	0.000	0.000	0.000	0.000	0.000	0.000	0.000	0.000	0.000	0.000	0.000
98.0	0.000	0.000	0.000	0.000	0.000	0.000	0.000	0.000	0.000	0.000	0.000	0.000	0.000	0.000	0.000	0.000	0.000	0.000	0.000	0.000	0.000	0.000	0.000

- X-Axis: RPM
- Y-Axis: MAP (Manifold Air Pressure)
- Entry Point: Injection Time in ms

This map represents an alternative way to calibrate the ECU: depending on manifold air pressure (MAP) sensor, guarantees a better tuning at low RPM and TPS opening. it is applied when the conditions under the Speed density strategy (Configuration -> Parameters -> Strategies -> Injection strategy) are met, so when RPM and TPS are under the set thresholds.



8.2.1.4 – Injection crank correction (%)

- Injection trims
- Launch control
- Pre-injection*
- RPM limiter
- Strategies
 - Drop sensor*
 - Injection strategy
 - Injectors phase strategy
 - Neutral strategy*
 - Quickshift*
- Vb out
- CAN configuration
- CAN parameters
- Sensors
 - Engine water temperature sensor
 - Gear sensor
 - Intake air temperature sensor
 - Manifold air pressure sensor
 - Spare channel #1
 - Spare channel #2
 - Throttle position sensor
- Map 1 (Default map 1)**
 - Fuel
 - Injection main #1
 - Injection main speed-density
 - Injection crank correction**
 - Pre-injection
 - Compensations
 - Injector 1
 - Injector 2
 - Transient

Table 2D 3D

Map 1 - Fuel Injection crank correction (%)

°Fv	0	1	2	3	4	5	6	7	8	9	10	11	12	13	14	15	16	18	120	300
-40.0	152.0	155.0	158.0	159.0	159.0	158.5	157.8	154.9	150.8	145.7	140.9	137.7	137.7	137.5	137.5	137.5	137.5	141.5	145.5	145.5
-22.0	142.0	145.0	148.0	149.0	149.0	148.5	147.8	144.9	140.8	135.7	130.9	127.7	127.7	127.5	127.5	127.5	127.5	131.5	135.5	135.5
-4.0	132.0	135.0	138.0	139.0	139.0	138.5	137.8	134.9	130.8	125.7	120.9	117.7	117.7	117.5	117.5	117.5	117.5	121.5	125.5	125.5
14.0	122.0	125.0	128.0	129.0	129.0	128.5	127.8	124.9	120.8	115.7	110.9	107.7	107.7	107.5	107.5	107.5	107.5	111.5	115.5	115.5
32.0	109.0	113.0	117.0	119.0	120.0	119.5	117.8	114.9	109.8	103.7	95.9	89.7	88.7	88.5	88.5	88.5	89.5	96.5	102.5	102.5
50.0	97.0	101.0	105.0	108.0	110.0	109.5	108.8	104.9	99.8	91.7	84.9	78.7	75.7	74.5	74.5	74.5	76.5	82.5	88.5	88.5
68.0	82.0	87.0	92.0	95.0	97.0	97.5	95.8	92.9	86.8	78.7	69.9	64.7	63.7	63.5	63.5	63.5	64.5	67.5	69.5	69.5
86.0	53.0	59.0	63.0	66.0	67.0	66.5	63.8	59.9	55.8	50.7	45.9	40.7	35.7	33.5	32.5	32.5	32.5	33.5	38.5	45.0
104.0	26.0	28.0	30.0	31.0	31.0	33.0	38.0	42.0	45.0	46.0	43.0	38.0	25.0	15.0	15.0	15.0	15.0	17.0	23.0	30.0
122.0	22.0	24.0	27.0	27.0	26.0	27.0	33.0	39.0	43.0	44.0	43.0	38.0	25.0	15.0	15.0	15.0	15.0	15.0	15.0	30.0
131.0	22.0	24.0	27.0	27.0	26.0	27.0	33.0	39.0	43.0	44.0	43.0	38.0	25.0	15.0	15.0	15.0	15.0	15.0	15.0	0.0
140.0	20.0	21.0	23.0	24.0	22.0	22.0	28.0	34.0	38.0	39.0	38.0	33.0	25.0	15.0	15.0	15.0	15.0	15.0	15.0	0.0
149.0	20.0	21.0	23.0	24.0	22.0	22.0	28.0	34.0	38.0	39.0	38.0	33.0	25.0	15.0	15.0	15.0	15.0	15.0	15.0	0.0
158.0	10.0	9.0	12.5	10.5	10.5	11.0	14.0	17.0	19.0	19.5	19.0	16.5	12.5	7.5	7.5	7.5	7.5	7.5	7.5	0.0
167.0	0.0	0.0	0.0	0.0	0.0	0.0	0.0	0.0	0.0	0.0	0.0	0.0	0.0	0.0	0.0	0.0	0.0	0.0	0.0	0.0
176.0	0.0	0.0	0.0	0.0	0.0	0.0	0.0	0.0	0.0	0.0	0.0	0.0	0.0	0.0	0.0	0.0	0.0	0.0	0.0	0.0
185.0	0.0	0.0	0.0	0.0	0.0	0.0	0.0	0.0	0.0	0.0	0.0	0.0	0.0	0.0	0.0	0.0	0.0	0.0	0.0	0.0
194.0	0.0	0.0	0.0	0.0	0.0	0.0	0.0	0.0	0.0	0.0	0.0	0.0	0.0	0.0	0.0	0.0	0.0	0.0	0.0	0.0
203.0	0.0	0.0	0.0	0.0	0.0	0.0	0.0	0.0	0.0	0.0	0.0	0.0	0.0	0.0	0.0	0.0	0.0	0.0	0.0	0.0

- X-axis: Number of Revolutions (REV)
- Y-axis Engine Coolant Temperature ECT.
- Entry Point: injection percentual correction to apply at the main injection table.

This table is only applied at the engine crank for the maximum number of revolutions (end point of Revolution X-axis).

This strategy is deeply explained in Appendix F.

8.2.1.5 – Pre-injection (ms)

		Map 1 - Fuel.Pre-injection (ms)															
		5.0	26.6	32.0	37.4	48.2	57.2	68.0	75.2	93.2	102.2	150.8	152.6	179.6	210.2	253.4	285.8
ms\F		0.000	0.000	0.000	0.000	0.000	0.000	0.000	0.000	0.000	0.000	0.000	0.000	0.000	0.000	0.000	0.000

- X-axis: Engine Coolant Temperature ECT
- Entry Point: pre-injection durations in ms.

If Pre-injection strategy is enabled, this table is activated by the very first movement of the crankshaft and is applied just before the intervention of all the other tables (injection main / injection crank corrections).

This strategy is deeply explained in Appendix E.

8.2.1.6 – Compensations

Injection BAP correction (%)

All these tables are referred as corrections as to the main injection table.

Map 1 - Fuel.Compensations.Injection BAP correction (%)																
%kPa	40.0	45.0	50.0	55.0	60.0	65.0	70.0	75.0	80.0	85.0	90.0	95.0	100.0	105.0	110.0	120.0
	-50.0	-50.0	-50.0	-45.0	-40.0	-37.0	-32.0	-27.0	-22.0	-17.0	-10.0	-5.0	0.0	0.0	5.0	10.0

- X-axis: Barometric pressure
- Entry Point: percentage of fuel correction.

Injection EWT correction (%)

Map 1 - Fuel.Compensations.Injection EWT correction (%)																
%\F	-22.0	-4.0	14.0	32.0	50.0	68.0	86.0	104.0	122.0	140.0	158.0	176.0	194.0	212.0	230.0	248.0
	80.0	70.0	65.0	60.0	55.0	40.0	30.0	25.0	18.0	15.0	0.0	0.0	0.0	0.0	0.0	0.0

- X-axis: Engine Water Temperature
- Entry Point: percentage of fuel correction.

Injection IAT correction (%)

Table		Map 1 - Fuel.Compensations.Injection IAT correction (%)															
%\F	-22.0	-4.0	14.0	32.0	50.0	68.0	86.0	104.0	122.0	140.0	158.0	176.0	194.0	194.0	194.0	194.0	
	10.0	8.0	6.0	4.0	2.0	1.0	0.0	-1.0	-2.0	-3.0	-4.0	-5.0	-6.0	-7.0	-8.0	-9.0	

- X-axis: Intake Air temperature
- Entry Point: percentage of fuel correction.

8.2.1.7 – Injector 1

Injector 1 battery correction (ms)

Table		Map 1 - Fuel.Injector 1.Injector 1 battery correction (ms)															
ms\V	8.000	8.500	9.000	9.500	10.000	10.500	11.000	11.500	12.000	12.500	13.000	13.500	14.000	14.500	15.000	15.500	
	2.500	2.336	2.171	2.007	1.842	1.678	1.513	1.349	1.184	1.020	1.020	1.020	1.000	0.893	0.893	0.893	

- X-axis: battery voltage
- Entry Point: injection time offset in ms.

This strategy is deeply explained in Appendix G.

Injector 1 phase (phase°)

Tps (%)	500	1000	1500	2000	2500	3000	3500	4000	4500	5000	5500	6000	6500	7000	7500	8000	8500	9000	9500	10000	10500	11000
0.0	-92.0	-92.0	-92.0	-92.0	-92.0	-93.0	-93.0	-93.0	-93.0	-94.0	-94.0	-94.0	-95.0	-94.0	-95.0	-95.0	-96.0	-96.0	-96.0	-96.0	-97.0	-96.0
2.5	-92.0	-92.0	-92.0	-92.0	-92.0	-93.0	-93.0	-93.0	-94.0	-94.0	-94.0	-95.0	-95.0	-94.0	-95.0	-95.0	-96.0	-96.0	-97.0	-96.0	-96.0	-96.0
5.0	-92.0	-92.0	-92.0	-92.0	-92.0	-93.0	-93.0	-93.0	-94.0	-94.0	-94.0	-95.0	-95.0	-94.0	-95.0	-96.0	-95.0	-96.0	-96.0	-95.0	-96.0	-96.0
10.0	-92.0	-92.0	-92.0	-92.0	-92.0	-93.0	-93.0	-94.0	-94.0	-94.0	-95.0	-94.0	-94.0	-95.0	-94.0	-96.0	-96.0	-96.0	-97.0	-97.0	-98.0	-98.0
25.0	-92.0	-92.0	-92.0	-92.0	-93.0	-93.0	-92.0	-92.0	-94.0	-95.0	-95.0	-98.0	-95.0	-96.0	-97.0	-97.0	-97.0	-98.0	-97.0	-98.0	-98.0	-98.0
33.0	-92.0	-92.0	-92.0	-92.0	-93.0	-92.0	-92.0	-94.0	-95.0	-95.0	-96.0	-97.0	-101.0	-102.0	-102.0	-103.0	-103.0	-103.0	-104.0	-104.0	-104.0	-104.0
50.0	-92.0	-92.0	-92.0	-92.0	-93.0	-91.0	-92.0	-92.0	-94.0	-95.0	-95.0	-100.0	-111.0	-121.0	-132.0	-138.0	-143.0	-143.0	-144.0	-144.0	-144.0	-144.0
66.0	-92.0	-92.0	-92.0	-92.0	-93.0	-92.0	-92.0	-94.0	-95.0	-105.0	-116.0	-126.0	-137.0	-147.0	-158.0	-164.0	-165.0	-166.0	-166.0	-166.0	-166.0	-166.0
75.0	-92.0	-92.0	-92.0	-92.0	-92.0	-91.0	-92.0	-92.0	-100.0	-105.0	-115.0	-125.0	-137.0	-146.0	-162.0	-168.0	-169.0	-169.0	-170.0	-171.0	-170.0	-170.0
100.0	-92.0	-92.0	-92.0	-92.0	-93.0	-92.0	-92.0	-92.0	-105.0	-115.0	-125.0	-141.0	-151.0	-162.0	-177.0	-178.0	-179.0	-179.0	-179.0	-179.0	-221.0	-220.0

This table is based on X-axis with RPM and Y-axis with TPS. Depending on the injector operating strategy selected (Configuration → Parameters → Strategies) the entry value in this table is the end or the start angle of the injection phase.

- X-axis = RPM.
- Y-axis = TPS.
- Entry Point = end or the start angle of the injection phase.

8.2.1.8 – Injector 2

This section appears only if you have an OEM 2nd injector or if you have selected the proper option in Configuration → Strategies → Motorcycle setup

Injector 2 battery correction (ms)

ms/V	8.000	8.500	9.000	9.500	10.000	10.500	11.000	11.500	12.000	12.500	13.000	13.500	14.000	14.500	15.000	15.500
0.000	0.000	0.000	0.000	0.000	0.000	0.000	0.000	0.000	0.000	0.000	0.000	0.000	0.000	0.000	0.000	0.000

- X-axis: battery voltage
- Entry Point: injection time offset in ms.

This strategy is deeply explained in Appendix G.



Injector 2 percentage (%)

Table		2D	3D																																																																																																																																																																																																																																																																																			
<div style="display: flex; justify-content: space-between;"> <div style="width: 25%;"> <ul style="list-style-type: none"> GasGas - MC 250F 2021 Configuration Map 1 (Default map 1) <ul style="list-style-type: none"> Fuel <ul style="list-style-type: none"> Injection main #1 Injection main speed-density Injection crank correction Pre-injection Compensations Injector 1 Injector 2 <ul style="list-style-type: none"> Injector 2 battery correction Injector 2 percentage Injector 2 phase Transient Ignition Quickshift Map 2 (Default map 2) Map 3 (Default map 3) Map 4 (Default map 4) Map 5 (Default map 5) Map 6 (Default map 6) Expansions </div> <div style="width: 75%;"> <p style="text-align: center;">Map 1 - Fuel.Injector 2.Injector 2 percentage (%)</p> <table border="1"> <thead> <tr> <th>Tps (%) \rpm</th> <th>250</th><th>500</th><th>750</th><th>1000</th><th>1250</th><th>1500</th><th>1750</th><th>2000</th><th>2250</th><th>2500</th><th>2750</th><th>3000</th><th>3250</th><th>3500</th><th>3750</th><th>4000</th><th>4250</th><th>4500</th><th>4750</th><th>5000</th><th>5250</th><th>5500</th><th>5750</th><th>6000</th> </tr> </thead> <tbody> <tr><td>0.0</td><td>0.0</td><td>0.0</td><td>0.0</td><td>0.0</td><td>0.0</td><td>0.0</td><td>0.0</td><td>0.0</td><td>0.0</td><td>0.0</td><td>0.0</td><td>0.0</td><td>0.0</td><td>0.0</td><td>0.0</td><td>0.0</td><td>0.0</td><td>0.0</td><td>0.0</td><td>0.0</td><td>0.0</td><td>0.0</td><td>0.0</td><td>0.0</td></tr> <tr><td>2.5</td><td>0.0</td><td>0.0</td><td>0.0</td><td>0.0</td><td>0.0</td><td>0.0</td><td>0.0</td><td>0.0</td><td>0.0</td><td>0.0</td><td>0.0</td><td>0.0</td><td>0.0</td><td>0.0</td><td>0.0</td><td>0.0</td><td>0.0</td><td>0.0</td><td>0.0</td><td>0.0</td><td>0.0</td><td>0.0</td><td>0.0</td><td>0.0</td></tr> <tr><td>5.0</td><td>0.0</td><td>0.0</td><td>0.0</td><td>0.0</td><td>0.0</td><td>0.0</td><td>0.0</td><td>0.0</td><td>0.0</td><td>0.0</td><td>0.0</td><td>0.0</td><td>0.0</td><td>0.0</td><td>0.0</td><td>0.0</td><td>0.0</td><td>0.0</td><td>0.0</td><td>0.0</td><td>0.0</td><td>0.0</td><td>0.0</td><td>0.0</td></tr> <tr><td>10.0</td><td>0.0</td><td>0.0</td><td>0.0</td><td>0.0</td><td>0.0</td><td>0.0</td><td>0.0</td><td>0.0</td><td>0.0</td><td>0.0</td><td>0.0</td><td>0.0</td><td>0.0</td><td>0.0</td><td>0.0</td><td>0.0</td><td>0.0</td><td>0.0</td><td>0.0</td><td>0.0</td><td>0.0</td><td>0.0</td><td>0.0</td><td>0.0</td></tr> <tr><td>25.0</td><td>0.0</td><td>0.0</td><td>0.0</td><td>0.0</td><td>0.0</td><td>0.0</td><td>0.0</td><td>0.0</td><td>0.0</td><td>0.0</td><td>0.0</td><td>0.0</td><td>0.0</td><td>0.0</td><td>0.0</td><td>0.0</td><td>0.0</td><td>0.0</td><td>0.0</td><td>0.0</td><td>0.0</td><td>0.0</td><td>0.0</td><td>0.0</td></tr> <tr><td>33.0</td><td>0.0</td><td>0.0</td><td>0.0</td><td>0.0</td><td>0.0</td><td>0.0</td><td>0.0</td><td>0.0</td><td>0.0</td><td>0.0</td><td>0.0</td><td>0.0</td><td>0.0</td><td>0.0</td><td>0.0</td><td>0.0</td><td>0.0</td><td>0.0</td><td>0.0</td><td>0.0</td><td>0.0</td><td>0.0</td><td>0.0</td><td>0.0</td></tr> <tr><td>50.0</td><td>0.0</td><td>0.0</td><td>0.0</td><td>0.0</td><td>0.0</td><td>0.0</td><td>0.0</td><td>0.0</td><td>0.0</td><td>0.0</td><td>0.0</td><td>0.0</td><td>0.0</td><td>0.0</td><td>0.0</td><td>0.0</td><td>0.0</td><td>0.0</td><td>0.0</td><td>0.0</td><td>0.0</td><td>0.0</td><td>0.0</td><td>0.0</td></tr> <tr><td>66.0</td><td>0.0</td><td>0.0</td><td>0.0</td><td>0.0</td><td>0.0</td><td>0.0</td><td>0.0</td><td>0.0</td><td>0.0</td><td>0.0</td><td>0.0</td><td>0.0</td><td>0.0</td><td>0.0</td><td>0.0</td><td>0.0</td><td>0.0</td><td>0.0</td><td>0.0</td><td>0.0</td><td>0.0</td><td>0.0</td><td>0.0</td><td>0.0</td></tr> <tr><td>75.0</td><td>0.0</td><td>0.0</td><td>0.0</td><td>0.0</td><td>0.0</td><td>0.0</td><td>0.0</td><td>0.0</td><td>0.0</td><td>0.0</td><td>0.0</td><td>0.0</td><td>0.0</td><td>0.0</td><td>0.0</td><td>0.0</td><td>0.0</td><td>0.0</td><td>0.0</td><td>0.0</td><td>0.0</td><td>0.0</td><td>0.0</td><td>0.0</td></tr> <tr><td>100.0</td><td>0.0</td><td>0.0</td><td>0.0</td><td>0.0</td><td>0.0</td><td>0.0</td><td>0.0</td><td>0.0</td><td>0.0</td><td>0.0</td><td>0.0</td><td>0.0</td><td>0.0</td><td>0.0</td><td>0.0</td><td>0.0</td><td>0.0</td><td>0.0</td><td>0.0</td><td>0.0</td><td>0.0</td><td>0.0</td><td>0.0</td><td>0.0</td></tr> </tbody> </table> </div> </div>				Tps (%) \rpm	250	500	750	1000	1250	1500	1750	2000	2250	2500	2750	3000	3250	3500	3750	4000	4250	4500	4750	5000	5250	5500	5750	6000	0.0	0.0	0.0	0.0	0.0	0.0	0.0	0.0	0.0	0.0	0.0	0.0	0.0	0.0	0.0	0.0	0.0	0.0	0.0	0.0	0.0	0.0	0.0	0.0	0.0	2.5	0.0	0.0	0.0	0.0	0.0	0.0	0.0	0.0	0.0	0.0	0.0	0.0	0.0	0.0	0.0	0.0	0.0	0.0	0.0	0.0	0.0	0.0	0.0	0.0	5.0	0.0	0.0	0.0	0.0	0.0	0.0	0.0	0.0	0.0	0.0	0.0	0.0	0.0	0.0	0.0	0.0	0.0	0.0	0.0	0.0	0.0	0.0	0.0	0.0	10.0	0.0	0.0	0.0	0.0	0.0	0.0	0.0	0.0	0.0	0.0	0.0	0.0	0.0	0.0	0.0	0.0	0.0	0.0	0.0	0.0	0.0	0.0	0.0	0.0	25.0	0.0	0.0	0.0	0.0	0.0	0.0	0.0	0.0	0.0	0.0	0.0	0.0	0.0	0.0	0.0	0.0	0.0	0.0	0.0	0.0	0.0	0.0	0.0	0.0	33.0	0.0	0.0	0.0	0.0	0.0	0.0	0.0	0.0	0.0	0.0	0.0	0.0	0.0	0.0	0.0	0.0	0.0	0.0	0.0	0.0	0.0	0.0	0.0	0.0	50.0	0.0	0.0	0.0	0.0	0.0	0.0	0.0	0.0	0.0	0.0	0.0	0.0	0.0	0.0	0.0	0.0	0.0	0.0	0.0	0.0	0.0	0.0	0.0	0.0	66.0	0.0	0.0	0.0	0.0	0.0	0.0	0.0	0.0	0.0	0.0	0.0	0.0	0.0	0.0	0.0	0.0	0.0	0.0	0.0	0.0	0.0	0.0	0.0	0.0	75.0	0.0	0.0	0.0	0.0	0.0	0.0	0.0	0.0	0.0	0.0	0.0	0.0	0.0	0.0	0.0	0.0	0.0	0.0	0.0	0.0	0.0	0.0	0.0	0.0	100.0	0.0	0.0	0.0	0.0	0.0	0.0	0.0	0.0	0.0	0.0	0.0	0.0	0.0	0.0	0.0	0.0	0.0	0.0	0.0	0.0	0.0	0.0	0.0	0.0
Tps (%) \rpm	250	500	750	1000	1250	1500	1750	2000	2250	2500	2750	3000	3250	3500	3750	4000	4250	4500	4750	5000	5250	5500	5750	6000																																																																																																																																																																																																																																																														
0.0	0.0	0.0	0.0	0.0	0.0	0.0	0.0	0.0	0.0	0.0	0.0	0.0	0.0	0.0	0.0	0.0	0.0	0.0	0.0	0.0	0.0	0.0	0.0	0.0																																																																																																																																																																																																																																																														
2.5	0.0	0.0	0.0	0.0	0.0	0.0	0.0	0.0	0.0	0.0	0.0	0.0	0.0	0.0	0.0	0.0	0.0	0.0	0.0	0.0	0.0	0.0	0.0	0.0																																																																																																																																																																																																																																																														
5.0	0.0	0.0	0.0	0.0	0.0	0.0	0.0	0.0	0.0	0.0	0.0	0.0	0.0	0.0	0.0	0.0	0.0	0.0	0.0	0.0	0.0	0.0	0.0	0.0																																																																																																																																																																																																																																																														
10.0	0.0	0.0	0.0	0.0	0.0	0.0	0.0	0.0	0.0	0.0	0.0	0.0	0.0	0.0	0.0	0.0	0.0	0.0	0.0	0.0	0.0	0.0	0.0	0.0																																																																																																																																																																																																																																																														
25.0	0.0	0.0	0.0	0.0	0.0	0.0	0.0	0.0	0.0	0.0	0.0	0.0	0.0	0.0	0.0	0.0	0.0	0.0	0.0	0.0	0.0	0.0	0.0	0.0																																																																																																																																																																																																																																																														
33.0	0.0	0.0	0.0	0.0	0.0	0.0	0.0	0.0	0.0	0.0	0.0	0.0	0.0	0.0	0.0	0.0	0.0	0.0	0.0	0.0	0.0	0.0	0.0	0.0																																																																																																																																																																																																																																																														
50.0	0.0	0.0	0.0	0.0	0.0	0.0	0.0	0.0	0.0	0.0	0.0	0.0	0.0	0.0	0.0	0.0	0.0	0.0	0.0	0.0	0.0	0.0	0.0	0.0																																																																																																																																																																																																																																																														
66.0	0.0	0.0	0.0	0.0	0.0	0.0	0.0	0.0	0.0	0.0	0.0	0.0	0.0	0.0	0.0	0.0	0.0	0.0	0.0	0.0	0.0	0.0	0.0	0.0																																																																																																																																																																																																																																																														
75.0	0.0	0.0	0.0	0.0	0.0	0.0	0.0	0.0	0.0	0.0	0.0	0.0	0.0	0.0	0.0	0.0	0.0	0.0	0.0	0.0	0.0	0.0	0.0	0.0																																																																																																																																																																																																																																																														
100.0	0.0	0.0	0.0	0.0	0.0	0.0	0.0	0.0	0.0	0.0	0.0	0.0	0.0	0.0	0.0	0.0	0.0	0.0	0.0	0.0	0.0	0.0	0.0	0.0																																																																																																																																																																																																																																																														

This table defines the percentual repartition between the two injectors.

- X-axis = RPM.
- Y-axis = TPS.
- Entry Point = percentage of the fuel to the second injector

Injector 2 phase (phase°)

Table		2D	3D																																																																																																																																																																																																																																																																								
<div style="display: flex; justify-content: space-between;"> <div style="width: 25%;"> <ul style="list-style-type: none"> GasGas - MC 250F 2021 Configuration Map 1 (Default map 1) <ul style="list-style-type: none"> Fuel <ul style="list-style-type: none"> Injection main #1 Injection main speed-density Injection crank correction Pre-injection Compensations Injector 1 Injector 2 <ul style="list-style-type: none"> Injector 2 battery correction Injector 2 percentage Injector 2 phase Transient Ignition Quickshift Map 2 (Default map 2) Map 3 (Default map 3) Map 4 (Default map 4) Map 5 (Default map 5) Map 6 (Default map 6) Expansions </div> <div style="width: 75%;"> <p style="text-align: center;">Map 1 - Fuel.Injector 2.Injector 2 phase (Phase (°))</p> <table border="1"> <thead> <tr> <th>Tps (%) \rpm</th> <th>500</th><th>1000</th><th>1500</th><th>2000</th><th>2500</th><th>3000</th><th>3500</th><th>4000</th><th>4500</th><th>5000</th><th>5500</th><th>6000</th><th>6500</th><th>7000</th><th>7500</th><th>8000</th><th>8500</th><th>9000</th><th>9500</th><th>10000</th><th>10500</th><th>11000</th><th>11500</th> </tr> </thead> <tbody> <tr><td>0.0</td><td>0.0</td><td>0.0</td><td>0.0</td><td>0.0</td><td>0.0</td><td>0.0</td><td>0.0</td><td>0.0</td><td>0.0</td><td>0.0</td><td>0.0</td><td>0.0</td><td>0.0</td><td>0.0</td><td>0.0</td><td>0.0</td><td>0.0</td><td>0.0</td><td>0.0</td><td>0.0</td><td>0.0</td><td>0.0</td><td>0.0</td></tr> <tr><td>2.5</td><td>0.0</td><td>0.0</td><td>0.0</td><td>0.0</td><td>0.0</td><td>0.0</td><td>0.0</td><td>0.0</td><td>0.0</td><td>0.0</td><td>0.0</td><td>0.0</td><td>0.0</td><td>0.0</td><td>0.0</td><td>0.0</td><td>0.0</td><td>0.0</td><td>0.0</td><td>0.0</td><td>0.0</td><td>0.0</td><td>0.0</td></tr> <tr><td>5.0</td><td>0.0</td><td>0.0</td><td>0.0</td><td>0.0</td><td>0.0</td><td>0.0</td><td>0.0</td><td>0.0</td><td>0.0</td><td>0.0</td><td>0.0</td><td>0.0</td><td>0.0</td><td>0.0</td><td>0.0</td><td>0.0</td><td>0.0</td><td>0.0</td><td>0.0</td><td>0.0</td><td>0.0</td><td>0.0</td><td>0.0</td></tr> <tr><td>10.0</td><td>0.0</td><td>0.0</td><td>0.0</td><td>0.0</td><td>0.0</td><td>0.0</td><td>0.0</td><td>0.0</td><td>0.0</td><td>0.0</td><td>0.0</td><td>0.0</td><td>0.0</td><td>0.0</td><td>0.0</td><td>0.0</td><td>0.0</td><td>0.0</td><td>0.0</td><td>0.0</td><td>0.0</td><td>0.0</td><td>0.0</td></tr> <tr><td>25.0</td><td>0.0</td><td>0.0</td><td>0.0</td><td>0.0</td><td>0.0</td><td>0.0</td><td>0.0</td><td>0.0</td><td>0.0</td><td>0.0</td><td>0.0</td><td>0.0</td><td>0.0</td><td>0.0</td><td>0.0</td><td>0.0</td><td>0.0</td><td>0.0</td><td>0.0</td><td>0.0</td><td>0.0</td><td>0.0</td><td>0.0</td></tr> <tr><td>33.0</td><td>0.0</td><td>0.0</td><td>0.0</td><td>0.0</td><td>0.0</td><td>0.0</td><td>0.0</td><td>0.0</td><td>0.0</td><td>0.0</td><td>0.0</td><td>0.0</td><td>0.0</td><td>0.0</td><td>0.0</td><td>0.0</td><td>0.0</td><td>0.0</td><td>0.0</td><td>0.0</td><td>0.0</td><td>0.0</td><td>0.0</td></tr> <tr><td>50.0</td><td>0.0</td><td>0.0</td><td>0.0</td><td>0.0</td><td>0.0</td><td>0.0</td><td>0.0</td><td>0.0</td><td>0.0</td><td>0.0</td><td>0.0</td><td>0.0</td><td>0.0</td><td>0.0</td><td>0.0</td><td>0.0</td><td>0.0</td><td>0.0</td><td>0.0</td><td>0.0</td><td>0.0</td><td>0.0</td><td>0.0</td></tr> <tr><td>66.0</td><td>0.0</td><td>0.0</td><td>0.0</td><td>0.0</td><td>0.0</td><td>0.0</td><td>0.0</td><td>0.0</td><td>0.0</td><td>0.0</td><td>0.0</td><td>0.0</td><td>0.0</td><td>0.0</td><td>0.0</td><td>0.0</td><td>0.0</td><td>0.0</td><td>0.0</td><td>0.0</td><td>0.0</td><td>0.0</td><td>0.0</td></tr> <tr><td>75.0</td><td>0.0</td><td>0.0</td><td>0.0</td><td>0.0</td><td>0.0</td><td>0.0</td><td>0.0</td><td>0.0</td><td>0.0</td><td>0.0</td><td>0.0</td><td>0.0</td><td>0.0</td><td>0.0</td><td>0.0</td><td>0.0</td><td>0.0</td><td>0.0</td><td>0.0</td><td>0.0</td><td>0.0</td><td>0.0</td><td>0.0</td></tr> <tr><td>100.0</td><td>0.0</td><td>0.0</td><td>0.0</td><td>0.0</td><td>0.0</td><td>0.0</td><td>0.0</td><td>0.0</td><td>0.0</td><td>0.0</td><td>0.0</td><td>0.0</td><td>0.0</td><td>0.0</td><td>0.0</td><td>0.0</td><td>0.0</td><td>0.0</td><td>0.0</td><td>0.0</td><td>0.0</td><td>0.0</td><td>0.0</td></tr> </tbody> </table> </div> </div>				Tps (%) \rpm	500	1000	1500	2000	2500	3000	3500	4000	4500	5000	5500	6000	6500	7000	7500	8000	8500	9000	9500	10000	10500	11000	11500	0.0	0.0	0.0	0.0	0.0	0.0	0.0	0.0	0.0	0.0	0.0	0.0	0.0	0.0	0.0	0.0	0.0	0.0	0.0	0.0	0.0	0.0	0.0	0.0	2.5	0.0	0.0	0.0	0.0	0.0	0.0	0.0	0.0	0.0	0.0	0.0	0.0	0.0	0.0	0.0	0.0	0.0	0.0	0.0	0.0	0.0	0.0	0.0	5.0	0.0	0.0	0.0	0.0	0.0	0.0	0.0	0.0	0.0	0.0	0.0	0.0	0.0	0.0	0.0	0.0	0.0	0.0	0.0	0.0	0.0	0.0	0.0	10.0	0.0	0.0	0.0	0.0	0.0	0.0	0.0	0.0	0.0	0.0	0.0	0.0	0.0	0.0	0.0	0.0	0.0	0.0	0.0	0.0	0.0	0.0	0.0	25.0	0.0	0.0	0.0	0.0	0.0	0.0	0.0	0.0	0.0	0.0	0.0	0.0	0.0	0.0	0.0	0.0	0.0	0.0	0.0	0.0	0.0	0.0	0.0	33.0	0.0	0.0	0.0	0.0	0.0	0.0	0.0	0.0	0.0	0.0	0.0	0.0	0.0	0.0	0.0	0.0	0.0	0.0	0.0	0.0	0.0	0.0	0.0	50.0	0.0	0.0	0.0	0.0	0.0	0.0	0.0	0.0	0.0	0.0	0.0	0.0	0.0	0.0	0.0	0.0	0.0	0.0	0.0	0.0	0.0	0.0	0.0	66.0	0.0	0.0	0.0	0.0	0.0	0.0	0.0	0.0	0.0	0.0	0.0	0.0	0.0	0.0	0.0	0.0	0.0	0.0	0.0	0.0	0.0	0.0	0.0	75.0	0.0	0.0	0.0	0.0	0.0	0.0	0.0	0.0	0.0	0.0	0.0	0.0	0.0	0.0	0.0	0.0	0.0	0.0	0.0	0.0	0.0	0.0	0.0	100.0	0.0	0.0	0.0	0.0	0.0	0.0	0.0	0.0	0.0	0.0	0.0	0.0	0.0	0.0	0.0	0.0	0.0	0.0	0.0	0.0	0.0	0.0	0.0
Tps (%) \rpm	500	1000	1500	2000	2500	3000	3500	4000	4500	5000	5500	6000	6500	7000	7500	8000	8500	9000	9500	10000	10500	11000	11500																																																																																																																																																																																																																																																				
0.0	0.0	0.0	0.0	0.0	0.0	0.0	0.0	0.0	0.0	0.0	0.0	0.0	0.0	0.0	0.0	0.0	0.0	0.0	0.0	0.0	0.0	0.0	0.0																																																																																																																																																																																																																																																				
2.5	0.0	0.0	0.0	0.0	0.0	0.0	0.0	0.0	0.0	0.0	0.0	0.0	0.0	0.0	0.0	0.0	0.0	0.0	0.0	0.0	0.0	0.0	0.0																																																																																																																																																																																																																																																				
5.0	0.0	0.0	0.0	0.0	0.0	0.0	0.0	0.0	0.0	0.0	0.0	0.0	0.0	0.0	0.0	0.0	0.0	0.0	0.0	0.0	0.0	0.0	0.0																																																																																																																																																																																																																																																				
10.0	0.0	0.0	0.0	0.0	0.0	0.0	0.0	0.0	0.0	0.0	0.0	0.0	0.0	0.0	0.0	0.0	0.0	0.0	0.0	0.0	0.0	0.0	0.0																																																																																																																																																																																																																																																				
25.0	0.0	0.0	0.0	0.0	0.0	0.0	0.0	0.0	0.0	0.0	0.0	0.0	0.0	0.0	0.0	0.0	0.0	0.0	0.0	0.0	0.0	0.0	0.0																																																																																																																																																																																																																																																				
33.0	0.0	0.0	0.0	0.0	0.0	0.0	0.0	0.0	0.0	0.0	0.0	0.0	0.0	0.0	0.0	0.0	0.0	0.0	0.0	0.0	0.0	0.0	0.0																																																																																																																																																																																																																																																				
50.0	0.0	0.0	0.0	0.0	0.0	0.0	0.0	0.0	0.0	0.0	0.0	0.0	0.0	0.0	0.0	0.0	0.0	0.0	0.0	0.0	0.0	0.0	0.0																																																																																																																																																																																																																																																				
66.0	0.0	0.0	0.0	0.0	0.0	0.0	0.0	0.0	0.0	0.0	0.0	0.0	0.0	0.0	0.0	0.0	0.0	0.0	0.0	0.0	0.0	0.0	0.0																																																																																																																																																																																																																																																				
75.0	0.0	0.0	0.0	0.0	0.0	0.0	0.0	0.0	0.0	0.0	0.0	0.0	0.0	0.0	0.0	0.0	0.0	0.0	0.0	0.0	0.0	0.0	0.0																																																																																																																																																																																																																																																				
100.0	0.0	0.0	0.0	0.0	0.0	0.0	0.0	0.0	0.0	0.0	0.0	0.0	0.0	0.0	0.0	0.0	0.0	0.0	0.0	0.0	0.0	0.0	0.0																																																																																																																																																																																																																																																				

Depending on the injector operating strategy selected (Configuration -> Parameters -> Strategies -> Injector phase strategy) the entry value in this table is the end or the start angle of the injection phase. This table is made of an X-axis with RPM and Y-axis with TPS.

- X-axis = RPM.
- Y-axis = TPS.
- Entry Point = end or the start angle of the injection phase.

8.2.1.9 – Transient

This function is the one relevant to transient injection mapping tables (transient corrections applied under conditions), these are separated for opening and closing throttle.

This strategy is deeply explained in Appendix I.

Injection opening transient correction.

Map 1 – Fuel.Transient.Injection opening transient correction																
Tps (%)	2.0	3.5	4.5	9.0	15.0	20.0	25.0	30.0	35.0	37.5	40.0	45.0	50.0	55.0	60.0	70.0
Opening speed (%/s)	190	300	320	600	850	950	1050	1100	1150	1200	1250	1300	1350	1400	1450	1520
Correction (%)	13.5	14.5	15.4	17.4	26.3	33.2	35.2	36.1	38.0	39.1	39.3	42.8	44.5	46.2	47.1	49.6
Correction time (r)	4	4	4	4	4	4	4	4	5	5	5	5	5	5	5	5

The table is composed by one X-axis with TPS and three rows of entries: **Opening speed (%/s)**, **Correction (%)** and **Correction period (Rev)**. The strategy works as follows: in dependence upon the throttle position (TPS), if its opening speed (dTPS) is over the corresponding value (in the second-row cell), a correction (in the third-row cell) is applied for a number of revolutions (in the fourth row cell).

Injection closing transient correction

Map 1 – Fuel.Transient.Injection closing transient correction																
Tps (%)	20.0	25.0	30.0	32.0	35.0	38.0	43.0	50.0	54.0	57.0	60.0	65.0	70.0	75.0	80.0	85.0
Closing speed (%/s)	-820	-750	-700	-688	-664	-650	-630	-570	-540	-470	-410	-400	-400	-400	-400	-400
Correction (%)	-19.0	-22.0	-27.0	-31.0	-35.0	-46.0	-47.0	-47.0	-48.0	-48.0	-49.0	-51.0	-52.0	-54.0	-51.0	-40.0
Correction time (r)	3	3	3	3	3	3	3	3	3	3	3	1	1	1	2	2

The table is composed by one X-axis with TPS and three rows of entries: **Closing speed (%/s)**, **Correction (%)** and **Correction period (Rev)**. The strategy works as follows: in dependence upon the throttle position (TPS), if its closing speed (dTPS) is below the corresponding value (in the second-row cell), a correction (in the third-row cell) is applied for a number of revolutions (in the fourth row cell).

8.2.2 – Ignition

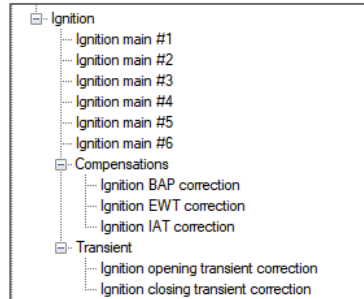

8.2.2.1 – Ignition main #1 alpha-n (Advance)

GasGas - MC 250F 2021

- Configuration
- Map 1 (Default map 1)*
 - Fuel
 - Ignition
 - Ignition main #1
 - Ignition main #2
 - Ignition main #3
 - Ignition main #4
 - Ignition main #5
 - Ignition main #6
 - Compensations
 - Transient
 - Launch control
 - Quickshift
 - Traction control
- Map 2 (Default map 2)
- Map 3 (Default map 3)
- Map 4 (Default map 4)
- Map 5 (Default map 5)
- Map 6 (Default map 6)
- Expansions

Table 2D 3D

Map 1 - Ignition.Ignition main #1 (Advance (°))

Tps (%) vpm	250	500	750	1000	1250	1500	1750	2000	2250	2500	2750	3000	3250	3500	3750	4000	4250	4500	4750	5000	5250	5500	5750	6000
0.0	9.0	9.0	9.0	9.0	10.4	10.1	10.2	10.5	10.5	10.3	11.0	13.7	17.4	21.7	25.3	30.0	34.3	38.9	41.9	44.8	46.5	47.8	48.4	4
2.5	9.0	9.0	9.0	9.0	10.4	10.1	10.3	10.5	10.5	10.3	11.1	12.7	15.3	19.6	25.2	29.9	34.6	38.8	41.8	44.7	46.4	47.7	48.4	4
5.0	9.0	9.0	9.0	9.0	15.0	14.8	15.0	15.1	15.0	15.0	15.5	15.3	17.3	20.0	25.0	28.8	33.3	38.0	40.3	43.0	44.0	45.1	45.9	4
10.0	9.0	9.0	9.0	9.0	19.7	19.4	19.5	19.7	19.8	19.6	19.7	21.2	23.1	26.1	30.4	34.6	38.0	41.6	43.6	45.4	46.9	48.0	48.7	4
25.0	9.0	9.0	9.0	9.0	11.6	11.3	11.5	11.7	11.7	11.5	10.4	12.0	15.1	18.4	21.7	24.5	26.7	29.8	31.6	33.3	35.1	36.5	37.2	3
33.0	9.0	9.0	9.0	9.0	10.4	10.1	10.3	10.6	10.5	10.3	10.3	11.1	13.5	15.9	17.8	19.8	20.9	22.6	24.5	26.6	28.3	30.6	31.4	3
50.0	9.0	9.0	9.0	9.0	13.2	12.9	13.0	13.2	13.3	13.3	13.8	14.5	17.2	20.0	21.7	22.3	22.4	23.0	23.5	24.0	25.0	25.5	26.1	2
66.0	9.0	9.0	9.0	9.0	13.5	13.3	13.4	13.7	13.6	13.7	13.5	15.8	19.1	22.5	25.6	27.1	27.9	29.4	29.9	30.4	30.6	30.3	30.2	3
75.0	9.0	9.0	9.0	9.0	11.2	11.1	11.2	11.3	11.4	12.1	13.1	16.1	19.4	22.4	25.2	26.9	27.9	29.8	31.0	32.0	32.2	32.1	31.8	3
100.0	9.0	9.0	9.0	9.0	9.1	8.9	9.0	9.1	9.5	10.6	12.3	16.8	20.0	23.1	26.2	29.0	31.4	34.2	34.6	35.4	35.5	35.5	34.5	3

This table is based on RPM (X-axis) and TPS (Y-axis), the entry is the ignition advance in degrees (°). In case of gear dependant setting, this table is used only for the first gear, otherwise is applied for all gears.

Ignition main #2 alpha-n (Advance°)

Ignition main #3 alpha-n (Advance°)

Ignition main #4 alpha-n (Advance°)

Ignition main #5 alpha-n (Advance°)

Ignition main #6 alpha-n (Advance°)

These tables are applied to the corresponding gear (2 to 6), only if the Map strategy to apply is Gear based.

8.2.2.2 – Ignition user compensation

The ignition user compensation table is a correction table where you can correct the advance in degrees for each map. The thresholds to be respected are between 3.0 ° and -5.0° in term of advance. In other words, if you are adding in a point a -2° of advance the main ignition map is corrected by a -2° of advance in that exact point resulting in a delay in terms of ignition advance degrees. An example of an empty ignition user compensation table is shown below:

Table 2D 3D

Map 1 - Ignition.Ignition user compensation (Advance (°))

Tps (%)/rpm	1000	2000	3000	4000	5000	6000	7000	8000	9000	10000	11000	12000	13000	14000	15000	16000
0.0	0.0	0.0	0.0	0.0	0.0	0.0	0.0	0.0	0.0	0.0	0.0	0.0	0.0	0.0	0.0	0.0
2.5	0.0	0.0	0.0	0.0	0.0	0.0	0.0	0.0	0.0	0.0	0.0	0.0	0.0	0.0	0.0	0.0
5.0	0.0	0.0	0.0	0.0	0.0	0.0	0.0	0.0	0.0	0.0	0.0	0.0	0.0	0.0	0.0	0.0
10.0	0.0	0.0	0.0	0.0	0.0	0.0	0.0	0.0	0.0	0.0	0.0	0.0	0.0	0.0	0.0	0.0
25.0	0.0	0.0	0.0	0.0	0.0	0.0	0.0	0.0	0.0	0.0	0.0	0.0	0.0	0.0	0.0	0.0
33.0	0.0	0.0	0.0	0.0	0.0	0.0	0.0	0.0	0.0	0.0	0.0	0.0	0.0	0.0	0.0	0.0
50.0	0.0	0.0	0.0	0.0	0.0	0.0	0.0	0.0	0.0	0.0	0.0	0.0	0.0	0.0	0.0	0.0
66.0	0.0	0.0	0.0	0.0	0.0	0.0	0.0	0.0	0.0	0.0	0.0	0.0	0.0	0.0	0.0	0.0
75.0	0.0	0.0	0.0	0.0	0.0	0.0	0.0	0.0	0.0	0.0	0.0	0.0	0.0	0.0	0.0	0.0
100.0	0.0	0.0	0.0	0.0	0.0	0.0	0.0	0.0	0.0	0.0	0.0	0.0	0.0	0.0	0.0	0.0

8.2.2.3 – Ignition dwell time (Taipan Y/Yarara only)

In inductive systems, such as the Yamaha engines, the Ignition Dwell Time is the time needed to charge the coil as shown in the following image. More into detail, it is the length of time that current flows through the primary winding of the coil.

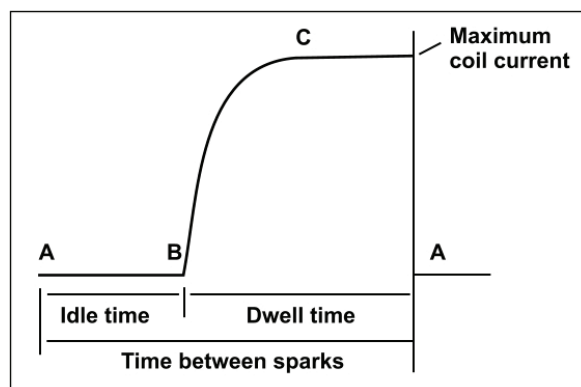

- 'A': the electronic switch opens, and the spark occurs.
- 'B': the electronic switch closes, and the current grows.
- 'C': the current reaches its peak.

The period B-A is the “Ignition Dwell Time” to be set in the following table.

The screenshot shows a software window titled 'New project - Spark 1.0.53.0 (Factory, access to all features)'. The left sidebar shows a tree view for 'Yamaha - YZ250F 2022' with 'Map 1 (Default map 1)' selected. The main area displays a table titled 'Map 1 - Ignition.Ignition dwell time (ms)'. The table has 17 columns representing voltage (ms/V) from 8.000 to 15.500. The first row shows values from 0.000 to 0.000. The second row shows values from 0.000 to 0.000. The status bar at the bottom indicates 'Taipan Y: ready for connection' and 'Running map'.

ms/V	8.000	8.500	9.000	9.500	10.000	10.500	11.000	11.500	12.000	12.500	13.000	13.500	14.000	14.500	15.000	15.500
	0.000	0.000	0.000	0.000	0.000	0.000	0.000	0.000	0.000	0.000	0.000	0.000	0.000	0.000	0.000	0.000
	0.000	0.000	0.000	0.000	0.000	0.000	0.000	0.000	0.000	0.000	0.000	0.000	0.000	0.000	0.000	0.000

As shown in the previous table, it is a compensation strategy that changes the time of charge of the coil in order to have the same condition of ignition even with low battery.

Please note that this battery compensation is available for Taipan Y and Yarara only since they have an inductive discharge ignition system as opposed to the Taipan that uses a capacitor discharge ignition system.

8.2.2.4 – Compensations

Ignition BAP correction (Advance°):

The screenshot shows a software window titled 'GasGas - MC 250F 2021'. The left sidebar shows a tree view for 'Map 1 (Default map 1)*' with 'Ignition BAP correction' selected. The main area displays a table titled 'Map 1 - Ignition.Compensations.Ignition BAP correction (Advance (°))'. The table has 17 columns representing barometric pressure (kPa) from 40.0 to 120.0. The first row shows values from 5.0 to 0.0. The second row shows values from 5.0 to 0.0. The status bar at the bottom indicates 'Running map'.

Advance (°)kPa	40.0	45.0	50.0	55.0	60.0	65.0	70.0	75.0	80.0	85.0	90.0	95.0	100.0	105.0	110.0	120.0
	5.0	5.0	5.0	5.0	5.0	5.0	5.0	4.0	3.0	2.0	1.0	0.0	0.0	0.0	0.0	0.0
	5.0	5.0	5.0	5.0	5.0	5.0	5.0	4.0	3.0	2.0	1.0	0.0	0.0	0.0	0.0	0.0

This table represents the Barometric Air Pressure contribution to ignition. This table is based on one X-axis with Barometric pressure and the entries are the angle degrees corrections to apply to the main ignition table.

This strategy is deeply explained in Appendix H.



Ignition EWT correction (Advance°)

Table		Map 1 - Ignition.Compensations.Ignition EWT correction (Advance (°))														
Advance (°)\°F	-22.0	-4.0	14.0	32.0	50.0	68.0	86.0	104.0	122.0	140.0	158.0	176.0	194.0	212.0	230.0	248.0
	5.0	5.0	5.0	5.0	5.0	4.0	2.0	2.0	0.0	0.0	0.0	0.0	0.0	0.0	0.0	0.0

This table represents the Engine Water Temperature (EWT) contribution to ignition. This table is based on one X-axis with EWT and the entries are the offset correction of angle degrees to apply to the main ignition table.

Ignition IAT correction (Advance °)

Table		Map 1 - Ignition.Compensations.Ignition IAT correction (Advance (°))														
Advance (°)\°F	-22.0	-4.0	14.0	32.0	50.0	68.0	86.0	104.0	122.0	140.0	158.0	176.0	194.0	194.0	194.0	194.0
	0.0	0.0	0.0	0.0	0.0	0.0	0.0	0.0	0.0	0.0	0.0	0.0	0.0	0.0	0.0	0.0

This table represents the Intake Air Temperature (IAT) contribution to ignition.
 X-axis = IAT
 Entry Points = angle degrees corrections to apply to the main ignition table.

8.2.2.5 – Transient

Ignition opening transient correction

Map 1 - Ignition.Transient.Ignition opening transient correction																
Tps (%)	2.0	3.5	4.5	9.0	15.0	20.0	25.0	30.0	35.0	37.5	40.0	45.0	50.0	55.0	60.0	70.0
Opening speed (%/s)	190	300	320	600	850	950	1050	1100	1150	1200	1250	1300	1350	1400	1450	1520
Correction advance (°)	0.0	0.0	0.0	0.0	0.0	0.0	0.0	0.0	0.0	0.0	0.0	0.0	0.0	0.0	0.0	0.0
Correction time (Rev)	1	1	1	1	1	1	1	1	1	1	1	1	1	1	1	1

The table is composed by one X-axis with TPS and three rows of entries: **Opening speed (%/s)**, **Correction Advance (°)** and **Correction time (Rev)**. The strategy works as follows: in dependence upon the throttle position (TPS), if its opening speed (dTPS) is over the corresponding value (in the second-row cell), a correction (in the third-row cell) is applied for a number of revolutions written in the fourth-row cell.

Ignition closing transient correction

Map 1 - Ignition.Transient.Ignition closing transient correction																
Tps (%)	20.0	25.0	30.0	32.0	35.0	38.0	43.0	50.0	54.0	57.0	60.0	65.0	70.0	75.0	80.0	85.0
Closing speed (%/s)	-820	-750	-700	-688	-664	-650	-630	-570	-540	-470	-410	-400	-400	-400	-400	-400
Correction advance (°)	0.0	0.0	0.0	0.0	0.0	0.0	0.0	0.0	0.0	0.0	0.0	0.0	0.0	0.0	0.0	0.0
Correction time (Rev)	1	1	1	1	1	1	1	1	1	1	1	1	1	1	1	1

The table is composed by one X-axis with TPS and three rows of entries: **Closing speed (%/s)**, **Correction Advance (°)** and **Correction time (Rev)**. The strategy works as follows: in dependence upon the throttle position (TPS), if its closing speed (dTPS) is below the corresponding value (in the second-row cell), a correction in terms of ignition advance (in the third-row cell) is applied for the number of revolutions written in the fourth row.

8.2.3 – Launch control

Launch control is an electronic aid to assist riders to accelerate from a standing start. This section is viewable only if enabled (click on the map chosen—launch control—enable). You can find the parameters to set the launch control strategy in Configuration → Parameters → Launch control.



8.2.3.1 – Injection launch control main table (ms)

Table		2D	3D																																																																																																																																																																																																																																																																								
<div style="display: flex; justify-content: space-between;"> <div style="width: 25%;"> <ul style="list-style-type: none"> GasGas - MC 250F 2021 Configuration Map 1 (Default map 1)* <ul style="list-style-type: none"> Fuel Ignition <ul style="list-style-type: none"> Ignition main #1 Ignition main #2 Ignition main #3 Ignition main #4 Ignition main #5 Ignition main #6 Compensations <ul style="list-style-type: none"> Transient Launch control <ul style="list-style-type: none"> Injection launch control main table Ignition launch control main table Quickshift Traction control Map 2 (Default map 2) </div> <div style="width: 75%;"> <p style="text-align: center;">Map 1 - Launch control.Injection launch control main table (ms)</p> <table border="1"> <thead> <tr> <th>Tps (%)/rpm</th> <th>250</th><th>500</th><th>750</th><th>1000</th><th>1250</th><th>1500</th><th>1750</th><th>2000</th><th>2250</th><th>2500</th><th>2750</th><th>3000</th><th>3250</th><th>3500</th><th>3750</th><th>4000</th><th>4250</th><th>4500</th><th>4750</th><th>5000</th><th>5250</th><th>5500</th><th>5750</th> </tr> </thead> <tbody> <tr><td>0.0</td><td>0.760</td><td>0.760</td><td>0.760</td><td>0.760</td><td>0.760</td><td>0.760</td><td>0.760</td><td>0.760</td><td>0.760</td><td>0.760</td><td>0.760</td><td>0.760</td><td>0.760</td><td>0.760</td><td>0.760</td><td>0.760</td><td>0.740</td><td>0.640</td><td>0.610</td><td>0.560</td><td>0.500</td><td>0.450</td><td>0.420</td></tr> <tr><td>2.5</td><td>1.180</td><td>1.180</td><td>1.180</td><td>1.180</td><td>1.180</td><td>1.180</td><td>1.180</td><td>1.062</td><td>1.053</td><td>1.044</td><td>1.071</td><td>1.062</td><td>1.053</td><td>0.999</td><td>0.963</td><td>0.945</td><td>0.909</td><td>0.872</td><td>0.828</td><td>0.761</td><td>0.709</td><td>0.655</td><td>0.615</td></tr> <tr><td>5.0</td><td>1.380</td><td>1.380</td><td>1.380</td><td>1.380</td><td>1.380</td><td>1.380</td><td>1.380</td><td>1.242</td><td>1.233</td><td>1.233</td><td>1.242</td><td>1.242</td><td>1.224</td><td>1.197</td><td>1.179</td><td>1.159</td><td>1.113</td><td>1.069</td><td>1.014</td><td>0.978</td><td>0.922</td><td>0.877</td><td>0.832</td></tr> <tr><td>10.0</td><td>1.840</td><td>1.840</td><td>1.840</td><td>1.840</td><td>1.840</td><td>1.840</td><td>1.840</td><td>1.840</td><td>1.860</td><td>1.940</td><td>1.970</td><td>1.930</td><td>1.850</td><td>1.720</td><td>1.640</td><td>1.550</td><td>1.490</td><td>1.440</td><td>1.410</td><td>1.380</td><td>1.360</td><td>1.330</td><td>1.290</td></tr> <tr><td>25.0</td><td>3.020</td><td>3.020</td><td>3.020</td><td>3.020</td><td>3.020</td><td>3.020</td><td>3.010</td><td>2.990</td><td>3.020</td><td>3.210</td><td>3.350</td><td>3.360</td><td>3.180</td><td>2.960</td><td>2.810</td><td>2.700</td><td>2.630</td><td>2.580</td><td>2.530</td><td>2.490</td><td>2.450</td><td>2.380</td><td>2.350</td></tr> <tr><td>33.0</td><td>3.510</td><td>3.510</td><td>3.510</td><td>3.510</td><td>3.510</td><td>3.510</td><td>3.480</td><td>3.440</td><td>3.470</td><td>3.560</td><td>3.570</td><td>3.610</td><td>3.490</td><td>3.120</td><td>3.030</td><td>2.990</td><td>2.950</td><td>2.910</td><td>2.900</td><td>2.890</td><td>2.890</td><td>2.880</td><td>2.900</td></tr> <tr><td>50.0</td><td>3.660</td><td>3.660</td><td>3.660</td><td>3.660</td><td>3.660</td><td>3.660</td><td>3.620</td><td>3.580</td><td>3.620</td><td>3.760</td><td>3.790</td><td>3.840</td><td>3.610</td><td>3.260</td><td>3.090</td><td>3.060</td><td>3.050</td><td>3.030</td><td>3.070</td><td>3.120</td><td>3.220</td><td>3.330</td><td>3.450</td></tr> <tr><td>66.0</td><td>3.750</td><td>3.750</td><td>3.750</td><td>3.750</td><td>3.750</td><td>3.750</td><td>3.710</td><td>3.670</td><td>3.720</td><td>3.880</td><td>4.000</td><td>3.970</td><td>3.670</td><td>3.350</td><td>3.150</td><td>3.100</td><td>3.100</td><td>3.110</td><td>3.130</td><td>3.150</td><td>3.270</td><td>3.390</td><td>3.530</td></tr> <tr><td>75.0</td><td>3.650</td><td>3.650</td><td>3.650</td><td>3.650</td><td>3.570</td><td>3.460</td><td>3.420</td><td>3.380</td><td>3.430</td><td>3.570</td><td>3.640</td><td>3.610</td><td>3.340</td><td>3.180</td><td>3.010</td><td>2.930</td><td>2.930</td><td>2.930</td><td>2.980</td><td>3.020</td><td>3.150</td><td>3.270</td><td>3.400</td></tr> <tr><td>100.0</td><td>3.570</td><td>3.570</td><td>3.570</td><td>3.570</td><td>3.380</td><td>3.260</td><td>3.230</td><td>3.150</td><td>3.230</td><td>3.380</td><td>3.410</td><td>3.390</td><td>3.210</td><td>3.010</td><td>2.860</td><td>2.720</td><td>2.700</td><td>2.680</td><td>2.680</td><td>2.700</td><td>2.860</td><td>3.030</td><td>3.030</td></tr> </tbody> </table> </div> </div>				Tps (%)/rpm	250	500	750	1000	1250	1500	1750	2000	2250	2500	2750	3000	3250	3500	3750	4000	4250	4500	4750	5000	5250	5500	5750	0.0	0.760	0.760	0.760	0.760	0.760	0.760	0.760	0.760	0.760	0.760	0.760	0.760	0.760	0.760	0.760	0.760	0.740	0.640	0.610	0.560	0.500	0.450	0.420	2.5	1.180	1.180	1.180	1.180	1.180	1.180	1.180	1.062	1.053	1.044	1.071	1.062	1.053	0.999	0.963	0.945	0.909	0.872	0.828	0.761	0.709	0.655	0.615	5.0	1.380	1.380	1.380	1.380	1.380	1.380	1.380	1.242	1.233	1.233	1.242	1.242	1.224	1.197	1.179	1.159	1.113	1.069	1.014	0.978	0.922	0.877	0.832	10.0	1.840	1.840	1.840	1.840	1.840	1.840	1.840	1.840	1.860	1.940	1.970	1.930	1.850	1.720	1.640	1.550	1.490	1.440	1.410	1.380	1.360	1.330	1.290	25.0	3.020	3.020	3.020	3.020	3.020	3.020	3.010	2.990	3.020	3.210	3.350	3.360	3.180	2.960	2.810	2.700	2.630	2.580	2.530	2.490	2.450	2.380	2.350	33.0	3.510	3.510	3.510	3.510	3.510	3.510	3.480	3.440	3.470	3.560	3.570	3.610	3.490	3.120	3.030	2.990	2.950	2.910	2.900	2.890	2.890	2.880	2.900	50.0	3.660	3.660	3.660	3.660	3.660	3.660	3.620	3.580	3.620	3.760	3.790	3.840	3.610	3.260	3.090	3.060	3.050	3.030	3.070	3.120	3.220	3.330	3.450	66.0	3.750	3.750	3.750	3.750	3.750	3.750	3.710	3.670	3.720	3.880	4.000	3.970	3.670	3.350	3.150	3.100	3.100	3.110	3.130	3.150	3.270	3.390	3.530	75.0	3.650	3.650	3.650	3.650	3.570	3.460	3.420	3.380	3.430	3.570	3.640	3.610	3.340	3.180	3.010	2.930	2.930	2.930	2.980	3.020	3.150	3.270	3.400	100.0	3.570	3.570	3.570	3.570	3.380	3.260	3.230	3.150	3.230	3.380	3.410	3.390	3.210	3.010	2.860	2.720	2.700	2.680	2.680	2.700	2.860	3.030	3.030
Tps (%)/rpm	250	500	750	1000	1250	1500	1750	2000	2250	2500	2750	3000	3250	3500	3750	4000	4250	4500	4750	5000	5250	5500	5750																																																																																																																																																																																																																																																				
0.0	0.760	0.760	0.760	0.760	0.760	0.760	0.760	0.760	0.760	0.760	0.760	0.760	0.760	0.760	0.760	0.760	0.740	0.640	0.610	0.560	0.500	0.450	0.420																																																																																																																																																																																																																																																				
2.5	1.180	1.180	1.180	1.180	1.180	1.180	1.180	1.062	1.053	1.044	1.071	1.062	1.053	0.999	0.963	0.945	0.909	0.872	0.828	0.761	0.709	0.655	0.615																																																																																																																																																																																																																																																				
5.0	1.380	1.380	1.380	1.380	1.380	1.380	1.380	1.242	1.233	1.233	1.242	1.242	1.224	1.197	1.179	1.159	1.113	1.069	1.014	0.978	0.922	0.877	0.832																																																																																																																																																																																																																																																				
10.0	1.840	1.840	1.840	1.840	1.840	1.840	1.840	1.840	1.860	1.940	1.970	1.930	1.850	1.720	1.640	1.550	1.490	1.440	1.410	1.380	1.360	1.330	1.290																																																																																																																																																																																																																																																				
25.0	3.020	3.020	3.020	3.020	3.020	3.020	3.010	2.990	3.020	3.210	3.350	3.360	3.180	2.960	2.810	2.700	2.630	2.580	2.530	2.490	2.450	2.380	2.350																																																																																																																																																																																																																																																				
33.0	3.510	3.510	3.510	3.510	3.510	3.510	3.480	3.440	3.470	3.560	3.570	3.610	3.490	3.120	3.030	2.990	2.950	2.910	2.900	2.890	2.890	2.880	2.900																																																																																																																																																																																																																																																				
50.0	3.660	3.660	3.660	3.660	3.660	3.660	3.620	3.580	3.620	3.760	3.790	3.840	3.610	3.260	3.090	3.060	3.050	3.030	3.070	3.120	3.220	3.330	3.450																																																																																																																																																																																																																																																				
66.0	3.750	3.750	3.750	3.750	3.750	3.750	3.710	3.670	3.720	3.880	4.000	3.970	3.670	3.350	3.150	3.100	3.100	3.110	3.130	3.150	3.270	3.390	3.530																																																																																																																																																																																																																																																				
75.0	3.650	3.650	3.650	3.650	3.570	3.460	3.420	3.380	3.430	3.570	3.640	3.610	3.340	3.180	3.010	2.930	2.930	2.930	2.980	3.020	3.150	3.270	3.400																																																																																																																																																																																																																																																				
100.0	3.570	3.570	3.570	3.570	3.380	3.260	3.230	3.150	3.230	3.380	3.410	3.390	3.210	3.010	2.860	2.720	2.700	2.680	2.680	2.700	2.860	3.030	3.030																																																																																																																																																																																																																																																				

If the Launch control strategy is enabled (Map n -> Launch control -> Enabled) and the corresponding conditions (in Configuration-> Parameters->Launch control) met and a proper switch (like the AiM Handlebar switch or the stock launch control switch if is present on the bike) is present on the motorbike (and the activation button is pressed) this table is applied. This is based on TPS (Y axis) and Rpm (X axis), the entry is the injection time in ms.

8.2.3.2 – Ignition launch control main table (Advance (°))

Table		2D	3D																																																																																																																																																																																																																																																																																			
<div style="display: flex; justify-content: space-between;"> <div style="width: 25%;"> <ul style="list-style-type: none"> GasGas - MC 250F 2021 Configuration Map 1 (Default map 1)* <ul style="list-style-type: none"> Fuel Ignition <ul style="list-style-type: none"> Ignition main #1 Ignition main #2 Ignition main #3 Ignition main #4 Ignition main #5 Ignition main #6 Compensations <ul style="list-style-type: none"> Transient Launch control <ul style="list-style-type: none"> Injection launch control main table Ignition launch control main table Quickshift Traction control Map 2 (Default map 2) Map 3 (Default map 3) </div> <div style="width: 75%;"> <p style="text-align: center;">Map 1 - Launch control.Ignition launch control main table (Advance (°))</p> <table border="1"> <thead> <tr> <th>Tps (%)/rpm</th> <th>250</th><th>500</th><th>750</th><th>1000</th><th>1250</th><th>1500</th><th>1750</th><th>2000</th><th>2250</th><th>2500</th><th>2750</th><th>3000</th><th>3250</th><th>3500</th><th>3750</th><th>4000</th><th>4250</th><th>4500</th><th>4750</th><th>5000</th><th>5250</th><th>5500</th><th>5750</th><th>6000</th> </tr> </thead> <tbody> <tr><td>0.0</td><td>9.0</td><td>9.0</td><td>9.0</td><td>9.0</td><td>10.4</td><td>10.1</td><td>10.2</td><td>10.5</td><td>10.5</td><td>10.3</td><td>11.0</td><td>13.7</td><td>17.4</td><td>21.7</td><td>25.3</td><td>30.0</td><td>34.3</td><td>38.9</td><td>41.9</td><td>44.8</td><td>46.5</td><td>47.8</td><td>48.4</td><td>4</td></tr> <tr><td>2.5</td><td>9.0</td><td>9.0</td><td>9.0</td><td>9.0</td><td>10.4</td><td>10.1</td><td>10.3</td><td>10.5</td><td>10.5</td><td>10.3</td><td>11.1</td><td>12.7</td><td>15.3</td><td>19.6</td><td>25.2</td><td>29.9</td><td>34.6</td><td>38.8</td><td>41.8</td><td>44.7</td><td>46.4</td><td>47.7</td><td>48.4</td><td>4</td></tr> <tr><td>5.0</td><td>9.0</td><td>9.0</td><td>9.0</td><td>9.0</td><td>15.0</td><td>14.8</td><td>15.0</td><td>15.1</td><td>15.0</td><td>15.0</td><td>15.5</td><td>15.3</td><td>17.3</td><td>20.0</td><td>25.0</td><td>28.8</td><td>33.3</td><td>38.0</td><td>40.3</td><td>43.0</td><td>44.0</td><td>45.1</td><td>45.9</td><td>4</td></tr> <tr><td>10.0</td><td>9.0</td><td>9.0</td><td>9.0</td><td>9.0</td><td>19.7</td><td>19.4</td><td>19.5</td><td>19.7</td><td>19.8</td><td>19.6</td><td>19.7</td><td>21.2</td><td>23.1</td><td>26.1</td><td>30.4</td><td>34.6</td><td>38.0</td><td>41.6</td><td>43.6</td><td>45.4</td><td>46.9</td><td>48.0</td><td>48.7</td><td>4</td></tr> <tr><td>25.0</td><td>9.0</td><td>9.0</td><td>9.0</td><td>9.0</td><td>11.6</td><td>11.3</td><td>11.5</td><td>11.7</td><td>11.7</td><td>11.5</td><td>10.4</td><td>12.0</td><td>15.1</td><td>18.4</td><td>21.7</td><td>24.5</td><td>26.7</td><td>29.8</td><td>31.6</td><td>33.3</td><td>35.1</td><td>36.5</td><td>37.2</td><td>3</td></tr> <tr><td>33.0</td><td>9.0</td><td>9.0</td><td>9.0</td><td>9.0</td><td>10.4</td><td>10.1</td><td>10.3</td><td>10.6</td><td>10.5</td><td>10.3</td><td>10.3</td><td>11.1</td><td>13.5</td><td>15.9</td><td>17.8</td><td>19.8</td><td>20.9</td><td>22.6</td><td>24.5</td><td>26.6</td><td>28.3</td><td>30.6</td><td>31.4</td><td>3</td></tr> <tr><td>50.0</td><td>9.0</td><td>9.0</td><td>9.0</td><td>9.0</td><td>13.2</td><td>12.9</td><td>13.0</td><td>13.2</td><td>13.3</td><td>13.3</td><td>13.8</td><td>14.5</td><td>17.2</td><td>20.0</td><td>21.7</td><td>22.3</td><td>22.4</td><td>23.0</td><td>23.5</td><td>24.0</td><td>25.0</td><td>25.5</td><td>26.1</td><td>2</td></tr> <tr><td>66.0</td><td>9.0</td><td>9.0</td><td>9.0</td><td>9.0</td><td>13.5</td><td>13.3</td><td>13.4</td><td>13.7</td><td>13.6</td><td>13.7</td><td>13.5</td><td>15.8</td><td>19.1</td><td>22.5</td><td>25.6</td><td>27.1</td><td>27.9</td><td>29.4</td><td>29.9</td><td>30.4</td><td>30.6</td><td>30.3</td><td>30.2</td><td>3</td></tr> <tr><td>75.0</td><td>9.0</td><td>9.0</td><td>9.0</td><td>9.0</td><td>11.2</td><td>11.1</td><td>11.2</td><td>11.3</td><td>11.4</td><td>12.1</td><td>13.1</td><td>16.1</td><td>19.4</td><td>22.4</td><td>25.2</td><td>26.9</td><td>27.9</td><td>29.8</td><td>31.0</td><td>32.0</td><td>32.2</td><td>32.1</td><td>31.8</td><td>3</td></tr> <tr><td>100.0</td><td>9.0</td><td>9.0</td><td>9.0</td><td>9.0</td><td>9.1</td><td>8.9</td><td>9.0</td><td>9.1</td><td>9.5</td><td>10.6</td><td>12.3</td><td>16.8</td><td>20.0</td><td>23.1</td><td>26.2</td><td>29.0</td><td>31.4</td><td>34.2</td><td>34.6</td><td>35.4</td><td>35.5</td><td>35.5</td><td>34.5</td><td>3</td></tr> </tbody> </table> </div> </div>				Tps (%)/rpm	250	500	750	1000	1250	1500	1750	2000	2250	2500	2750	3000	3250	3500	3750	4000	4250	4500	4750	5000	5250	5500	5750	6000	0.0	9.0	9.0	9.0	9.0	10.4	10.1	10.2	10.5	10.5	10.3	11.0	13.7	17.4	21.7	25.3	30.0	34.3	38.9	41.9	44.8	46.5	47.8	48.4	4	2.5	9.0	9.0	9.0	9.0	10.4	10.1	10.3	10.5	10.5	10.3	11.1	12.7	15.3	19.6	25.2	29.9	34.6	38.8	41.8	44.7	46.4	47.7	48.4	4	5.0	9.0	9.0	9.0	9.0	15.0	14.8	15.0	15.1	15.0	15.0	15.5	15.3	17.3	20.0	25.0	28.8	33.3	38.0	40.3	43.0	44.0	45.1	45.9	4	10.0	9.0	9.0	9.0	9.0	19.7	19.4	19.5	19.7	19.8	19.6	19.7	21.2	23.1	26.1	30.4	34.6	38.0	41.6	43.6	45.4	46.9	48.0	48.7	4	25.0	9.0	9.0	9.0	9.0	11.6	11.3	11.5	11.7	11.7	11.5	10.4	12.0	15.1	18.4	21.7	24.5	26.7	29.8	31.6	33.3	35.1	36.5	37.2	3	33.0	9.0	9.0	9.0	9.0	10.4	10.1	10.3	10.6	10.5	10.3	10.3	11.1	13.5	15.9	17.8	19.8	20.9	22.6	24.5	26.6	28.3	30.6	31.4	3	50.0	9.0	9.0	9.0	9.0	13.2	12.9	13.0	13.2	13.3	13.3	13.8	14.5	17.2	20.0	21.7	22.3	22.4	23.0	23.5	24.0	25.0	25.5	26.1	2	66.0	9.0	9.0	9.0	9.0	13.5	13.3	13.4	13.7	13.6	13.7	13.5	15.8	19.1	22.5	25.6	27.1	27.9	29.4	29.9	30.4	30.6	30.3	30.2	3	75.0	9.0	9.0	9.0	9.0	11.2	11.1	11.2	11.3	11.4	12.1	13.1	16.1	19.4	22.4	25.2	26.9	27.9	29.8	31.0	32.0	32.2	32.1	31.8	3	100.0	9.0	9.0	9.0	9.0	9.1	8.9	9.0	9.1	9.5	10.6	12.3	16.8	20.0	23.1	26.2	29.0	31.4	34.2	34.6	35.4	35.5	35.5	34.5	3
Tps (%)/rpm	250	500	750	1000	1250	1500	1750	2000	2250	2500	2750	3000	3250	3500	3750	4000	4250	4500	4750	5000	5250	5500	5750	6000																																																																																																																																																																																																																																																														
0.0	9.0	9.0	9.0	9.0	10.4	10.1	10.2	10.5	10.5	10.3	11.0	13.7	17.4	21.7	25.3	30.0	34.3	38.9	41.9	44.8	46.5	47.8	48.4	4																																																																																																																																																																																																																																																														
2.5	9.0	9.0	9.0	9.0	10.4	10.1	10.3	10.5	10.5	10.3	11.1	12.7	15.3	19.6	25.2	29.9	34.6	38.8	41.8	44.7	46.4	47.7	48.4	4																																																																																																																																																																																																																																																														
5.0	9.0	9.0	9.0	9.0	15.0	14.8	15.0	15.1	15.0	15.0	15.5	15.3	17.3	20.0	25.0	28.8	33.3	38.0	40.3	43.0	44.0	45.1	45.9	4																																																																																																																																																																																																																																																														
10.0	9.0	9.0	9.0	9.0	19.7	19.4	19.5	19.7	19.8	19.6	19.7	21.2	23.1	26.1	30.4	34.6	38.0	41.6	43.6	45.4	46.9	48.0	48.7	4																																																																																																																																																																																																																																																														
25.0	9.0	9.0	9.0	9.0	11.6	11.3	11.5	11.7	11.7	11.5	10.4	12.0	15.1	18.4	21.7	24.5	26.7	29.8	31.6	33.3	35.1	36.5	37.2	3																																																																																																																																																																																																																																																														
33.0	9.0	9.0	9.0	9.0	10.4	10.1	10.3	10.6	10.5	10.3	10.3	11.1	13.5	15.9	17.8	19.8	20.9	22.6	24.5	26.6	28.3	30.6	31.4	3																																																																																																																																																																																																																																																														
50.0	9.0	9.0	9.0	9.0	13.2	12.9	13.0	13.2	13.3	13.3	13.8	14.5	17.2	20.0	21.7	22.3	22.4	23.0	23.5	24.0	25.0	25.5	26.1	2																																																																																																																																																																																																																																																														
66.0	9.0	9.0	9.0	9.0	13.5	13.3	13.4	13.7	13.6	13.7	13.5	15.8	19.1	22.5	25.6	27.1	27.9	29.4	29.9	30.4	30.6	30.3	30.2	3																																																																																																																																																																																																																																																														
75.0	9.0	9.0	9.0	9.0	11.2	11.1	11.2	11.3	11.4	12.1	13.1	16.1	19.4	22.4	25.2	26.9	27.9	29.8	31.0	32.0	32.2	32.1	31.8	3																																																																																																																																																																																																																																																														
100.0	9.0	9.0	9.0	9.0	9.1	8.9	9.0	9.1	9.5	10.6	12.3	16.8	20.0	23.1	26.2	29.0	31.4	34.2	34.6	35.4	35.5	35.5	34.5	3																																																																																																																																																																																																																																																														

If the Launch control strategy is enabled (Map n -> Launch control -> Enabled), the corresponding conditions (in Configuration -> Parameters -> Launch control) are met and a proper switch (like the AiM Handlebar switch or the stock launch control switch if is present on the bike) is present on the motorcycle this table is applied. This table is based on TPS (Y axis) and Rpm (X axis) and the entry is the offset correction of angle degrees.

8.2.4 – Traction control

Table		2D	3D														
		Map 1 - Traction control.Traction control															
Tps (%)		0.0	2.5	5.0	8.0	10.0	12.0	15.0	20.0	25.0	30.0	40.0	50.0	60.0	70.0	80.0	90.0
rpm/s		0	0	0	0	0	0	0	0	0	0	0	0	0	0	0	0
Ignition advance offset (°)		0.0	0.0	0.0	0.0	0.0	0.0	0.0	0.0	0.0	0.0	0.0	0.0	0.0	0.0	0.0	0.0
Injection phase offset advance (°)		0.0	0.0	0.0	0.0	0.0	0.0	0.0	0.0	0.0	0.0	0.0	0.0	0.0	0.0	0.0	0.0
Correction maintenance (r)		0	0	0	0	0	0	0	0	0	0	0	0	0	0	0	0

Traction control is a system that stops the wheels of a vehicle from spinning when excess power is applied.

If the traction control strategy is enabled (Map -> Traction control -> Enable) and the corresponding conditions are met, this table is applied.

This is based on TPS (X axis) and four rows of entries:

- **Traction Control Factor (Rpm/s)**
- **Ignition advance offset (Advance (°)),**
- **Injection phase offset (Advance (°))**
- **Correction maintenance (Rev).**

8.2.4.1 – Traction control strategy

The traction control strategy has been designed in order to control the slipping of the rear wheel of the vehicle. A slipping wheel condition is necessarily transmitted to a sudden increase of the engine Rpm and therefore to a peak of engine acceleration. Therefore, our control strategy is based on monitoring the engine acceleration through a constant that from now on we will call “Traction Control factor” expressed in Rpm/s.

The TC factor has been used as threshold to activate or not the corrections of the traction control. In other words, it means that, if the ECU detects a Tc factor higher than the one set in the Traction control table, the corrections are activated. An example of an empty Traction control table is shown below:

Map 1 - Traction control.Traction control																
Tps (%)	0.0	2.5	5.0	8.0	10.0	12.0	15.0	20.0	25.0	30.0	40.0	50.0	60.0	70.0	80.0	90.0
rpm/s	0	0	0	0	0	0	0	0	0	0	0	0	0	0	0	0
Ignition advance offset (°)	0.0	0.0	0.0	0.0	0.0	0.0	0.0	0.0	0.0	0.0	0.0	0.0	0.0	0.0	0.0	0.0
Injection phase offset advance (°)	0.0	0.0	0.0	0.0	0.0	0.0	0.0	0.0	0.0	0.0	0.0	0.0	0.0	0.0	0.0	0.0
Correction maintenance (r)	0	0	0	0	0	0	0	0	0	0	0	0	0	0	0	0

Afterwards, since the traction corrections should provide less power to the vehicle, the rear wheel of the vehicle should regain grip and the engine acceleration should decrease as the Tc factor. By doing so, the ECU will continue to use the traction corrections until the Tc factor computed goes below the Tc factor threshold set in the Traction control table (first raw of the table).

At this point the previous corrections are maintained for a number of engine revolutions as set in the last raw of the Traction control table called “Correction maintenance(r)” (figure below).

Map 1 - Traction control.Traction control																
Tps (%)	0.0	2.5	5.0	8.0	10.0	12.0	15.0	20.0	25.0	30.0	40.0	50.0	60.0	70.0	80.0	90.0
rpm/s	0	0	0	0	0	0	0	0	0	0	0	0	0	0	0	0
Ignition advance offset (°)	0.0	0.0	0.0	0.0	0.0	0.0	0.0	0.0	0.0	0.0	0.0	0.0	0.0	0.0	0.0	0.0
Injection phase offset advance (°)	0.0	0.0	0.0	0.0	0.0	0.0	0.0	0.0	0.0	0.0	0.0	0.0	0.0	0.0	0.0	0.0
Correction maintenance (r)	0	0	0	0	0	0	0	0	0	0	0	0	0	0	0	0

Keep in mind that, a part of the engine revolutions set in the correction maintenance is used by the strategy to return linearly to the 0-correction condition. This has been used in order to have a transition between active and non-active correction condition as smooth as possible.

The Traction control corrections editable in Spark software are:

- The “Ignition advance offset (°)” that is an offset correction expressed in degrees for the Ignition advance, more into detail, for instance, if the value of this correction is -5° it means that the ECU is shifting forward the value of the main ignition advance table by a value of 5°, thus having a delay in the ignition advance.
- The “Injection phase offset advance (°)” that is an offset correction expressed in degrees for the injection phase advance, so, for instance, if the value of this correction is -35° it means that the ECU is shifting forward the value of the injector 1 phase table, thus having a delay in the injector phase.

Keep in mind that, if the vehicle has a second injector the traction control injection phase correction is acting on the main injector (Injector 1).

8.2.4.2 – Activate the traction control strategy

In order to activate the Traction control strategy, it is necessary to do a few mandatory things:

- Select “enabled” on the traction control strategy flag, corresponding to the map desired as shown below

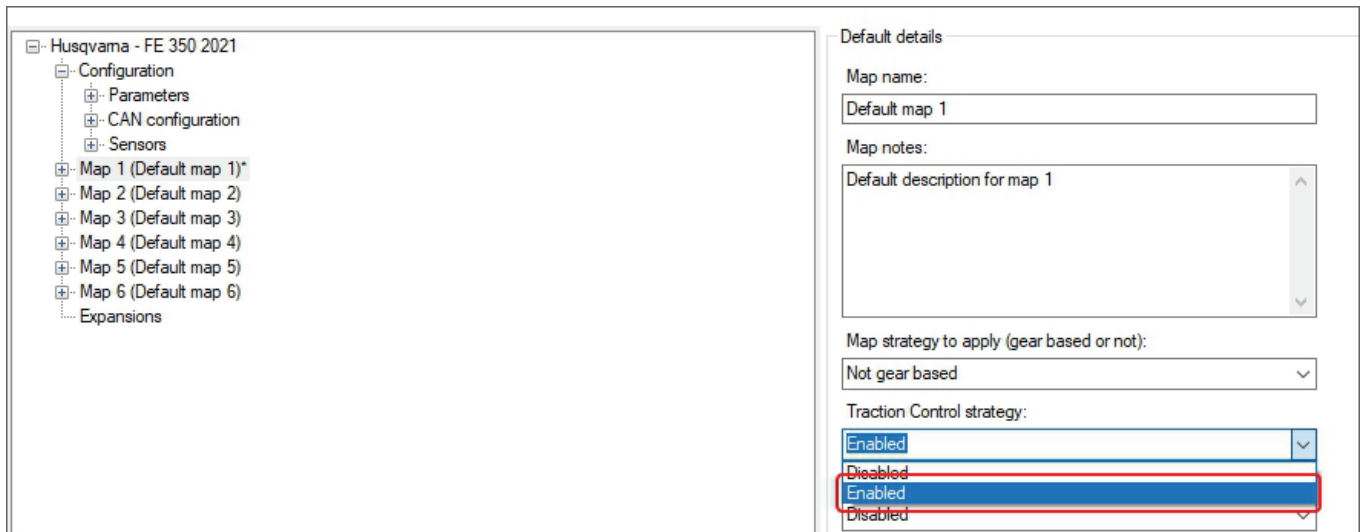

- Write to the ECU a map with a non-empty traction control table
- Activate the Traction control using the AiM HBS switch or using the standard button of the motorbike if provided by the manufacturer

Consider that if you are using the AiM HBS there are 5 levels of traction control selectable: with 1 being the minimum and 5 being the maximum. It means that level 5 of Traction control corresponds to the corrections set in the Traction control table of the corresponding map. Therefore, the other TC levels are a percentage of the Traction correction table that corresponds to the maximum, more into details:

- Level 5 – 100% Tc corrections
- Level 4 – 80% Tc corrections
- Level 3 – 60% Tc corrections
- Level 2 – 40% Tc corrections
- Level 1 – 20% Tc corrections

Please note that the Traction Control must be enabled for the selected Map: this will be done during the ECU Map configuration. To give a reference, it is shown below the Traction control table we provide for the motorcycle model Husqvarna – FE 350 2022.

		Map 1 - Traction control.Traction control															
Type (%)	18.0	20.0	25.0	30.0	35.0	40.0	45.0	50.0	55.0	60.0	65.0	70.0	75.0	80.0	85.0	90.0	
rpm/s	10000	1000	1500	3000	3250	3500	3750	4000	4250	4500	4750	5000	5250	5500	5750	6000	
Ignition advance offset (°)	0.0	-6.0	-8.0	-10.0	-10.0	-10.0	-10.0	-10.0	-10.0	-11.0	-11.0	-12.0	-12.0	-12.0	-12.0	-12.0	
Injection phase offset advance (°)	0.0	-35.0	-35.0	-45.0	-45.0	-45.0	-45.0	-45.0	-45.0	-45.0	-50.0	-50.0	-50.0	-50.0	-50.0	-50.0	
Correction maintenance (r)	20	20	20	15	15	15	15	15	15	15	15	10	10	10	10	10	

Before using the traction control strategy, make sure to have updated the firmware of the Taipan ECU.



8.2.4 – Quick shift

Quick shift is a strategy that works by reducing time of power loss between gear changes. This section is viewable only if enabled (click on Configuration -> Strategies -> Quick shift -> Enable). You can find the parameters to set the Quick shift strategy in Configuration -> Parameters -> Strategies -> Quick shift.

8.2.4.1 – Quick shift cut timetable (ms)

Tps (%)/rpm	500	1000	1500	2000	2500	3000	3500	4000	4500	5000	5500	6000	6500	7000	7500	8000	8500	9000	9500	10000
0.0	25.000	25.000	25.000	25.000	25.000	25.000	25.000	25.000	25.000	25.000	25.000	25.000	25.000	25.000	25.000	25.000	25.000	25.000	25.000	25.000
2.5	25.000	25.000	25.000	25.000	25.000	25.000	25.000	25.000	25.000	25.000	25.000	25.000	25.000	25.000	25.000	25.000	25.000	25.000	25.000	25.000
5.0	25.000	25.000	25.000	25.000	25.000	25.000	25.000	25.000	25.000	25.000	25.000	25.000	25.000	25.000	25.000	25.000	25.000	25.000	25.000	25.000
10.0	25.000	25.000	25.000	25.000	25.000	25.000	25.000	25.000	25.000	25.000	25.000	25.000	25.000	25.000	25.000	25.000	25.000	25.000	25.000	25.000
25.0	25.000	25.000	25.000	25.000	25.000	25.000	25.000	25.000	25.000	25.000	25.000	25.000	25.000	25.000	25.000	25.000	25.000	25.000	25.000	25.000
33.0	25.000	25.000	25.000	25.000	25.000	25.000	25.000	25.000	25.000	25.000	25.000	25.000	25.000	25.000	25.000	25.000	25.000	25.000	25.000	25.000
50.0	25.000	25.000	25.000	25.000	25.000	25.000	25.000	25.000	25.000	25.000	25.000	25.000	25.000	25.000	25.000	25.000	25.000	25.000	25.000	25.000
66.0	25.000	25.000	25.000	25.000	25.000	25.000	25.000	25.000	25.000	25.000	25.000	25.000	25.000	25.000	25.000	25.000	25.000	25.000	25.000	25.000
75.0	25.000	25.000	25.000	25.000	25.000	25.000	25.000	25.000	25.000	25.000	25.000	25.000	25.000	25.000	25.000	25.000	25.000	25.000	25.000	25.000
100.0	25.000	25.000	25.000	25.000	25.000	25.000	25.000	25.000	25.000	25.000	25.000	25.000	25.000	25.000	25.000	25.000	25.000	25.000	25.000	25.000

If the Quick shift strategy is enabled (Configuration -> Parameters -> Strategies -> Quick shift) and the corresponding conditions are met, this table is applied.

- X Axis = RPM
- Y Axis = TPS
- Entry points = cut times in ms, used during gear shifts.

8.3 – Expansions

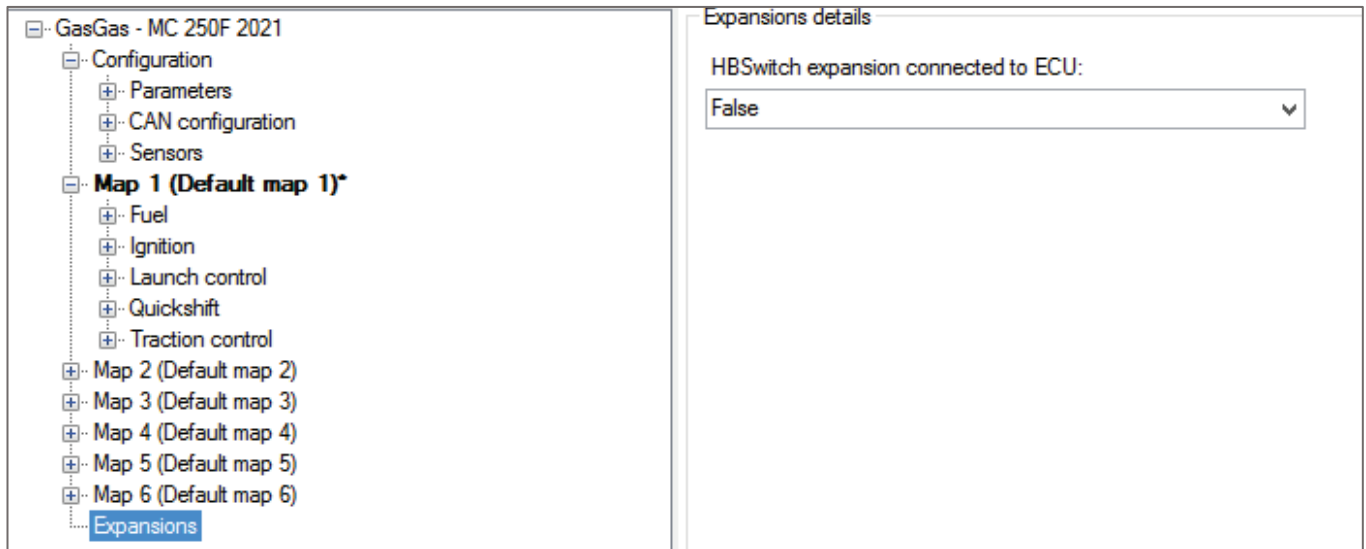

The screenshot displays the configuration interface for 'GasGas - MC 250F 2021'. The left pane shows a tree view with the following items:

- GasGas - MC 250F 2021
 - Configuration
 - Parameters
 - CAN configuration
 - Sensors
 - Map 1 (Default map 1)***
 - Fuel
 - Ignition
 - Launch control
 - Quickshift
 - Traction control
 - Map 2 (Default map 2)
 - Map 3 (Default map 3)
 - Map 4 (Default map 4)
 - Map 5 (Default map 5)
 - Map 6 (Default map 6)
 - Expansions**

The right pane, titled 'Expansions details', shows the following configuration:

HBSwitch expansion connected to ECU:
False

This section is made to enable the Handlebar switch.

9 – Data view – special key and visualization



The data view area can show the mapping tables in three different ways:

- Table Format
- 2D Format
- 3D Format (will be available soon)

It is possible to switch this view by pushing the tab placed on top of the data view area or using the shortcut: Ctrl button plus 1, 2 or 3 (1 for table view, 2 for 2D view and 3 for the 3D view).

9.1 - Table Format

This mode allows to type in the entry values in the cells, modify them and the breakpoints. The entries can be modified one by one, or grouped together, selecting. The selection on the table can be done with **shift + arrow** keys or using a mouse.

To select a group of entries:

- Left click and press for desired table zone (mouse)
- Shift + Arrows move for desired zone (keyboard)

Once elements (entries) are selected, it is possible to change their value in the following ways:

Mouse

- Right click (mouse) a pop-up is prompted to type the desired change.
 - Add -> algebraic addition of a defined quantity to the selected entry(s)
 - Add% -> percentual addition of a defined quantity to the selected entry(s)
 - Set -> forcing the desired value to the selected entry(s)

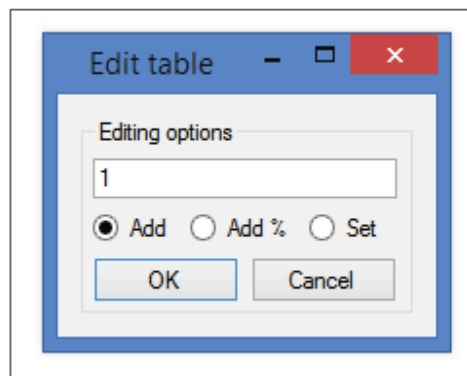

Keyboard

- Ctrl+Up -> Increment the selected entries for entry resolution x 10.
- Ctrl+Down -> Decrement the selected entries for entry resolution x 10.
- Alt+Up -> Increment the selected entries for entry resolution.
- Alt+Down -> Decrement the selected entries for entry resolution.
- Type in the value -> Force all entries to the desired number.

Once data have been changed, modified cells are highlighted in orange to show that the data is changed but not yet sent to the ECU. To send it to the ECU push enter on the keyboard, and the cells transmitted to the ECU are highlighted in green, to show that they have been written in temporary way. They have not been flashed into the ECU for permanent use.

To write the whole table directly into the ECU it is possible to select it clicking on the top left section. Then (with ECU connected and project opened) clicking the right button of the mouse on the map selected (left menu) you can directly write the whole table into the ECU.

Tps (%)/rpm	250	500	750	1000	1250	1500	1750	2000	2250
0.760	0.760	0.760	0.760	0.760	0.760	0.760	0.760	0.760	0.760
2.5	1.180	1.180	1.180	1.180	1.180	1.180	1.062	1.053	
5.0	1.380	1.200	1.380	1.380	1.380	1.380	1.242	1.233	
10.0	1.840	1.840	1.840	2.010	1.840	1.840	1.840	1.860	
25.0	3.020	3.020	3.020	3.020	3.020	3.010	2.990	3.020	
33.0	3.510	3.510	3.510	3.510	3.510	3.480	3.440	3.470	
50.0	3.660	3.660	3.660	3.660	3.660	3.620	3.580	3.620	
66.0	3.750	3.750	3.750	3.750	3.750	3.710	3.670	3.720	
75.0	3.650	3.650	3.650	3.650	3.570	3.480	3.380	3.430	
100.0	3.570	3.570	3.570	3.570	3.380	3.260	3.230	3.150	3.230

Tps (%)/rpm	250	500	750	1000	1250	1500	1750	2000	2250
0.760	0.760	0.760	0.760	0.760	0.760	0.760	0.760	0.760	0.760
2.5	1.180	1.180	1.180	1.180	1.180	1.180	1.062	1.053	
5.0	1.380	1.200	1.380	1.380	1.380	1.380	1.242	1.233	
10.0	1.840	1.840	1.840	2.010	1.840	1.840	1.840	1.860	
25.0	3.020	3.020	3.020	3.020	3.020	3.010	2.990	3.020	
33.0	3.510	3.510	3.510	3.510	3.510	3.480	3.440	3.470	
50.0	3.660	3.660	3.660	3.660	3.660	3.620	3.580	3.620	
66.0	3.750	3.750	3.750	3.750	3.750	3.710	3.670	3.720	
75.0	3.650	3.650	3.650	3.650	3.570	3.480	3.380	3.430	
100.0	3.570	3.570	3.570	3.570	3.380	3.260	3.230	3.150	3.230

Shortcuts for these tasks are available:

- Alt-Shift-T, to write the whole table.
- Alt-T, to read the whole table.

9.2 – 2D Format

To select the 2D graphs is possible:

Direct mouse selection (mouse). Once the mouse focus is on this window (click) move among graphs with the arrow keys (keyboard). Graphs can be modified point-by-point, after having selected the desired point:

Mouse

- Holding pressed the right button and dragging the line.

Keyboard

- Ctrl+Up -> Increment the selected entries for entry resolution (+ 0,1 per pressure)
- Ctrl+Down -> Decrement the selected entries for entry resolution (+ 0,1 per pressure)
- Alt+Up -> Increment the selected entries for entry resolution.
- Alt+Down -> Decrement the selected entries for entry resolution.

Once data have been changed in the 2D graph, to write them into the ECU return in the Table view and press the Enter Key.

In the Table view, breakpoints can be locked not to change them unintentionally. This is done ticking the flag at the right bottom corner of the Data view area.



To focus on a particular line, you can click on the line and press the shortcut Ctrl-Q. This hides the other lines. Use Ctrl-W to make them reappear.

9.3 – 3D Format

This feature will be uploaded soon. A proper function explanation will be prepared at that time.

10 – Live Measures view box

INJ1 time	--	ECT	--	IGN	--	Sync err	--
INJ1 phase	--	IAT	--	INJ base	--	Eng pos	--
INJ2 time	--	V ign	--	RPM	--	Eng state	--
INJ2 phase	--	λ	--	TPS	--	Eng revs	--

This area is used to monitor live data. Available parameters change according to the licence in use. This is activated only when the ECU is connected. Can be hidden/shown pressing the hide/show Live Measures panel button in the icon bar. Hiding this panel is recommended when the Data view area must be maximized.

Only if Live Measures is activated, live faults can be shown by the diagnostics section.



Live Measures parameters:

- **INJ1 time:** Total injector1 time of injection
- **INJ1 phase:** Injector 1 phase of injection
- **INJ2 time:** Total injector2 time of injection
- **INJ2 phase:** Injector 2 phase of injection
- **ECT:** Engine coolant temperature
- **IAT:** Intake air temperature
- **V ign:** Motorcycle ignition voltage
- **λ :** Lambda values (if ECU connected to an AiM logger that has LCU1 controller)
- **IGN:** Ignition advance
- **INJ base:** Injection base time from main table
- **RPM:** RPM at the moment
- **TPS:** Throttle position percentage at the moment
- **Sync err:** Synchronism errors
- **Eng pos:** Engine position, divided in Seek, Semi phased and Phased
- **Eng state:** Engine state divided in stop, cranking and running.
- **Eng revs:** Engine revolutions number

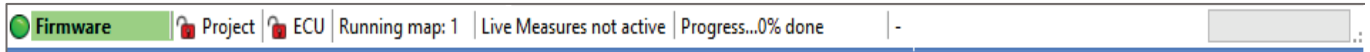
11 – Info bar



The bottom Info bar is a quick monitor for the ECU and software communication state. There are the following fields.

- Semaphore
 -  red light: the ECU is not recognized.
 -  orange blinking light: ECU is being recognized.
 -  green: the ECU is recognized.
- Ecu status (not connected or firmware, it depends on whether the control unit is connected. If the ecu is not connected you cannot write or flash anything in the ECU).
- Project (project locked by password or not).
- ECU (ECU target locked by password or not).
- Running map number
- Live Measures status (active – not active).
- Operation progress percentage
- Status bar showing the operation progress of a process (opposite corner in the bottom Info bar)



Appendix A – AiM ECUs ECU Part Numbers

XE1ECUCB0	ECU TAIPAN
XE1ECUCB1	ECU TAIPAN Y
XE1ECYYA0	ECU YARARA
XE1UCBT00	UC BRIDGE TUNER
XE1UCB000	UC BRIDGE
XE1HBS000	HANDLEBAR SWITCH
V02596090	ECU YARARA ADDITIONAL HARNESS

Appendix B – AiM ECUs and accessories dimensions and pinout

Taipan and Taipan Y dimensions in mm [inches]

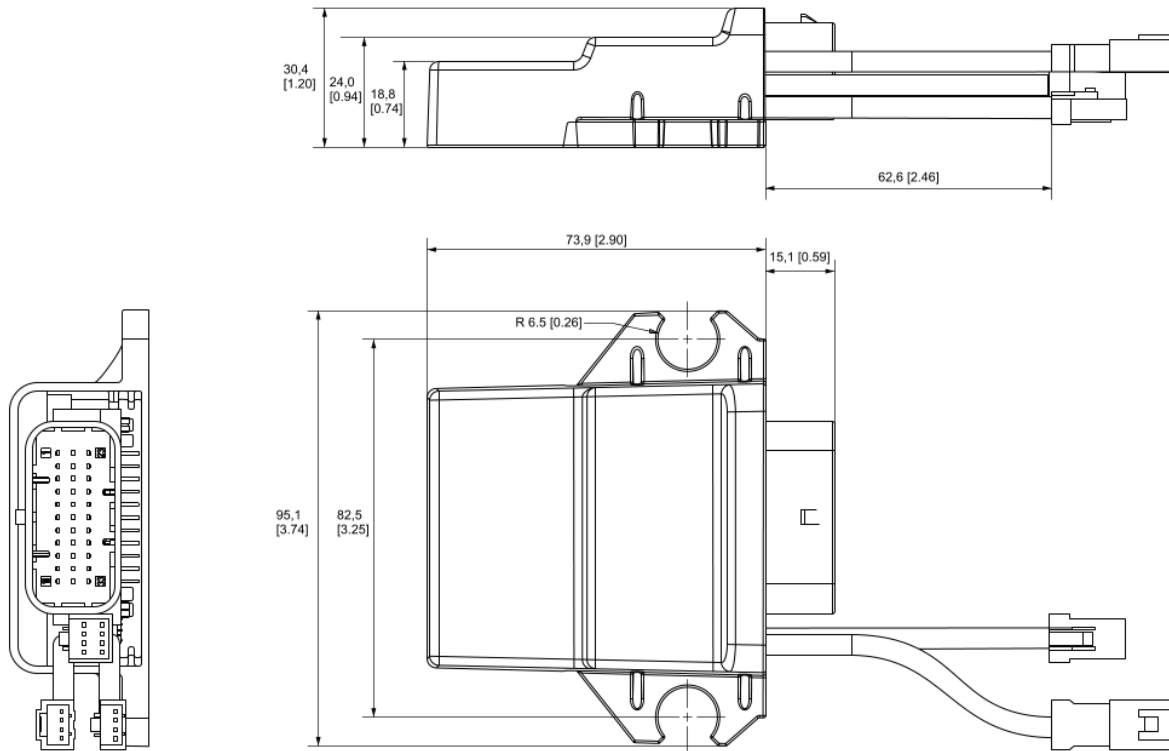

Yarara dimensions in mm [inches]

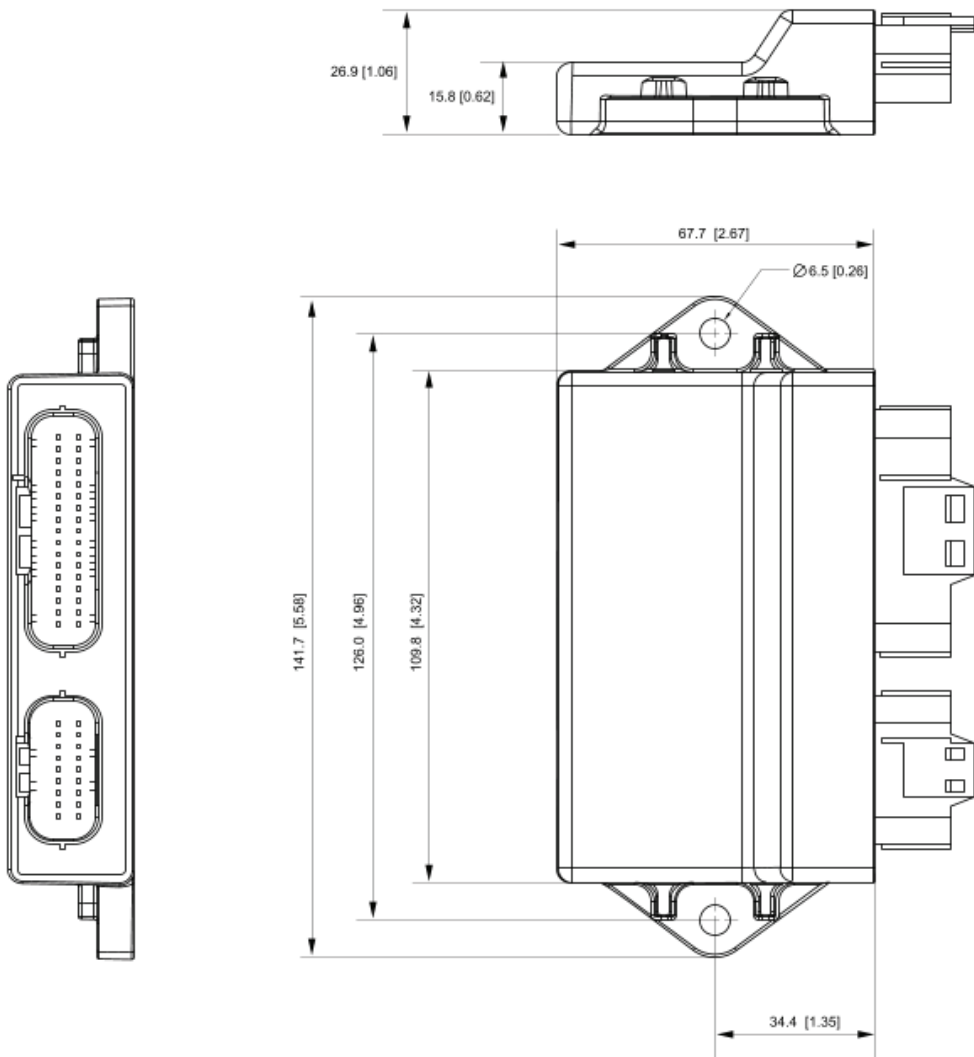



Handlebar Switch dimensions in mm [inches]

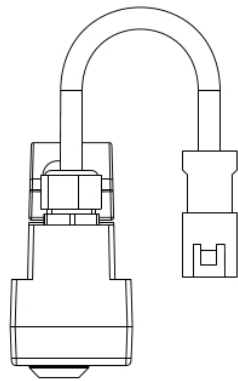
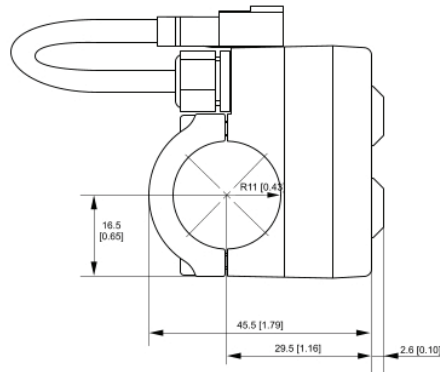
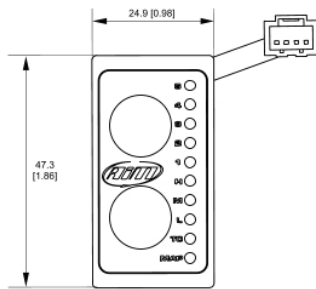

UC Bridge dimensions in mm [inches]

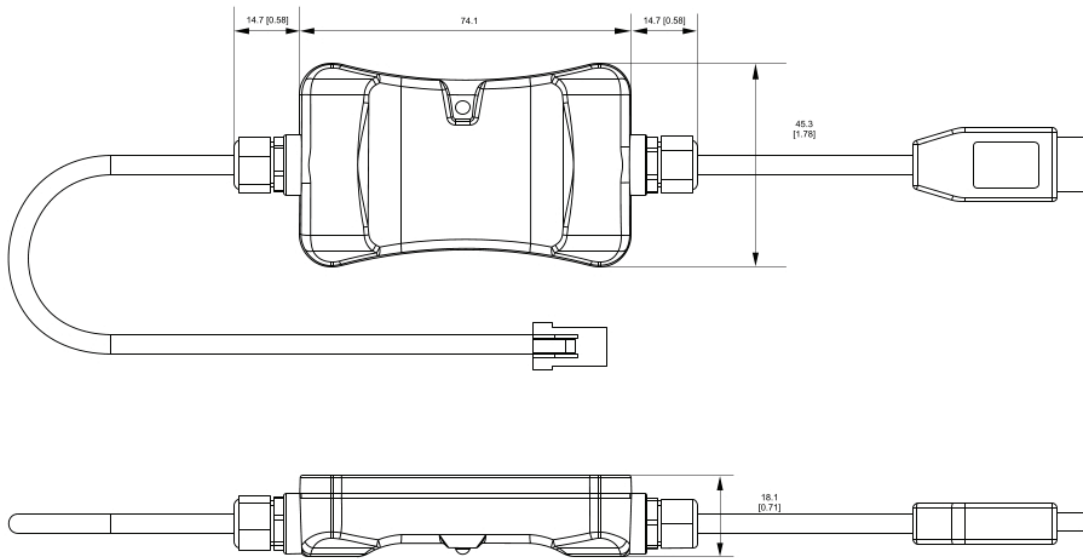

Taipan pinout

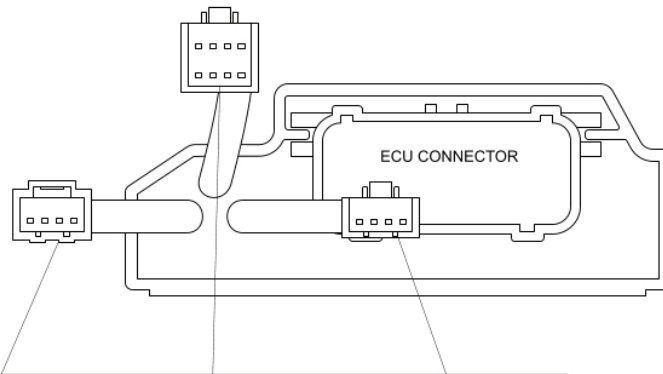

JST 04T-JWPF-VSLE-S CONNECTOR EXT VIEW	JST 08R-JWPF-VSLE-D CONNECTOR EXT VIEW	JST 04R-JWPF-VSLE-S CONNECTOR EXT VIEW
1 - GND 2 - CAN CAL HIGH 3 - CAN CAL LOW 4 - 12V IN	1 - 12V SECOND INJ 2 - LOW SIDE SECOND INJ 3 - LOW SIDE 4 - GND 5 - ANALOG INPUT 1 6 - ANALOG INPUT 2 7 - DNC 8 - DNC	1 - GND 2 - CAN EXP HIGH 3 - CAN EXP LOW 4 - 12V OUT (switched)

Taipan Y pinout

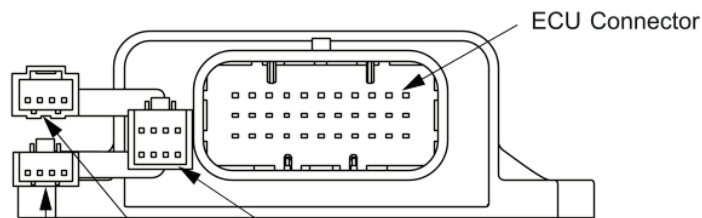

JST 04R-JWPF-VSLE-S CONNECTOR EXTERNAL VIEW	JST 04T-JWPF-VSLE-S CONNECTOR EXTERNAL VIEW	JST 08R-JWPF-VSLE-D CONNECTOR EXTERNAL VIEW
1 - GND 2 - CAN EXP. HIGH 3 - CAN EXP. LOW 4 - 12V OUT (switched)	1 - GND 2 - CAN CAL HIGH 3 - CAN CAL LOW 4 - 12V IN	1 - 12V SECOND INJ 2 - LOW SIDE SECOND INJ 3 - LOW SIDE 4 - GND 5 - ANALOG INPUT 1 6 - ANALOG INPUT 2 7 - VREF 8 - DNC

Yarara pinout

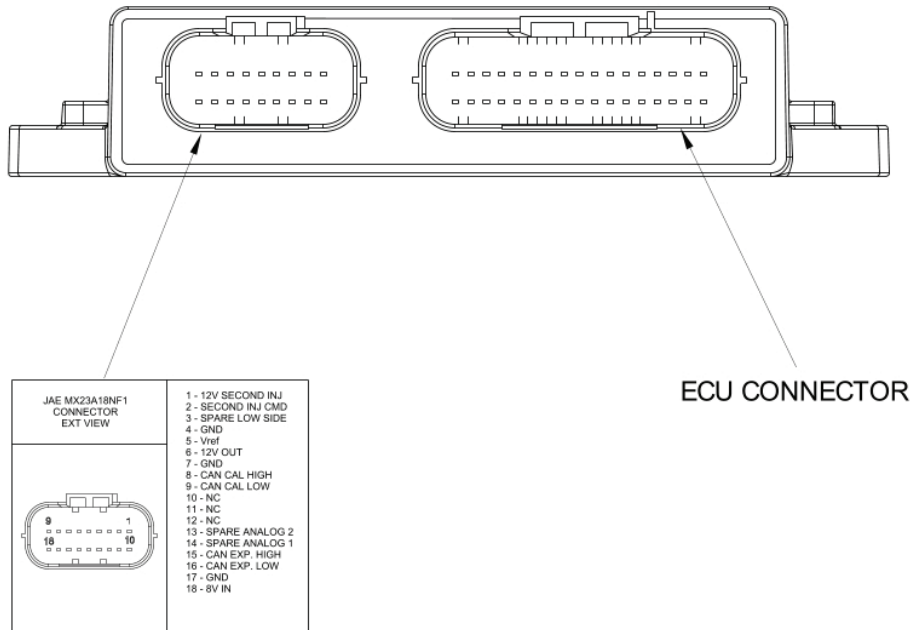

Handelbar Switch pinout

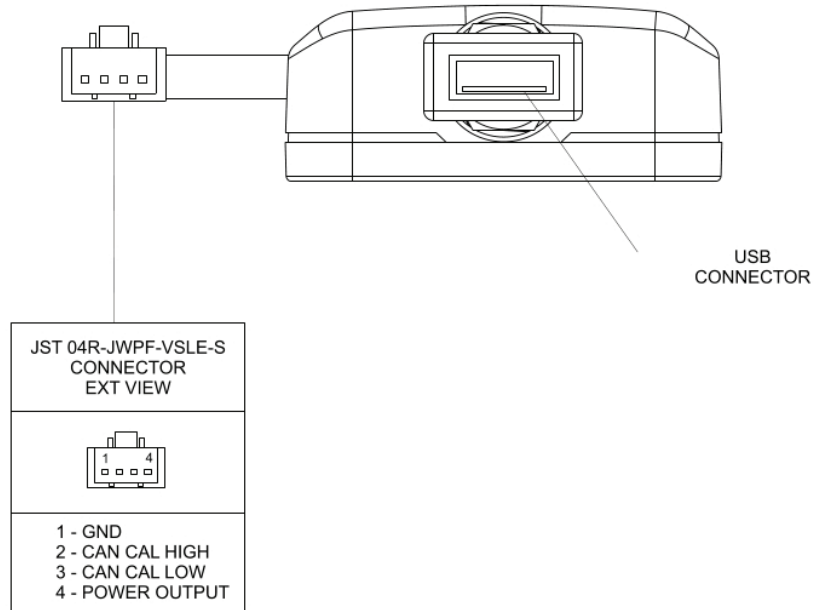

UC Bridge pinout

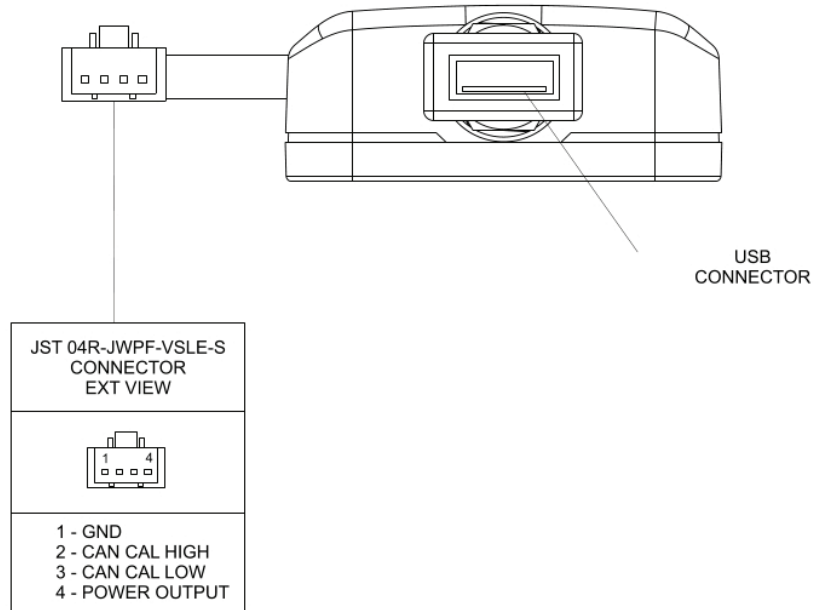

Appendix C – Taipan, Taipan Y and Yarara harnesses

Taipan and Taipan Y optional cables dimensions and pinout

1 UC Bridge extension cable 2 m
Part number V02596020

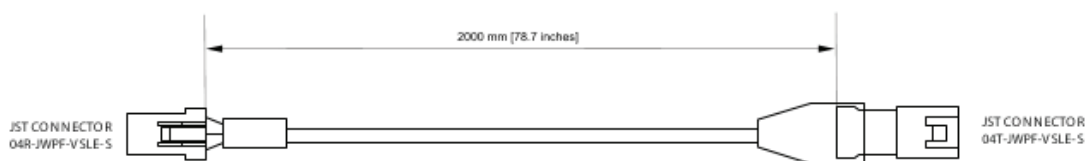

2 UC Bridge extension cable 4 m
Part number V02596030

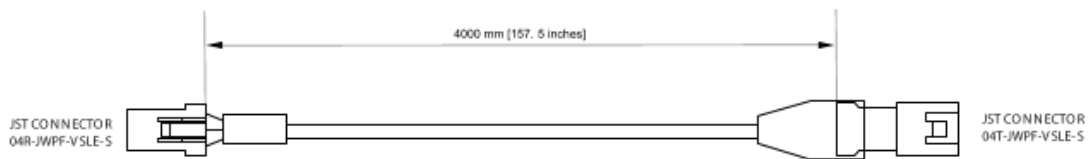

3 Solo 2 DL extension cable 50 cm
Part number V02589120

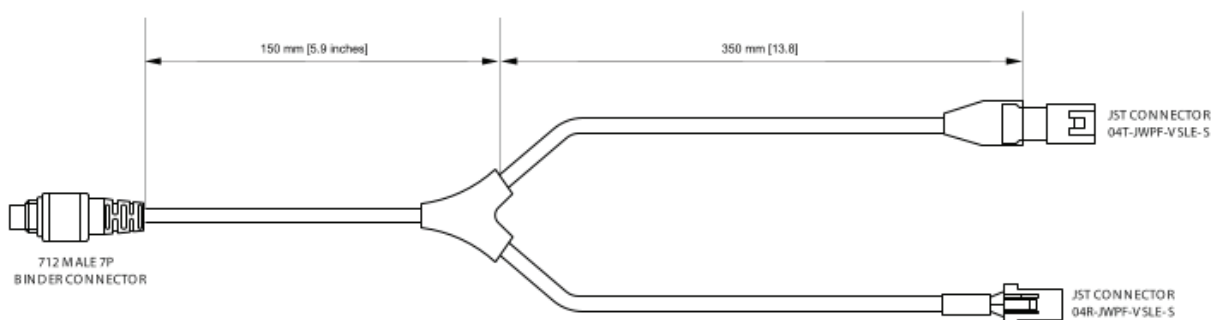

4 Analog channels and second injection harness

Part number V02596060

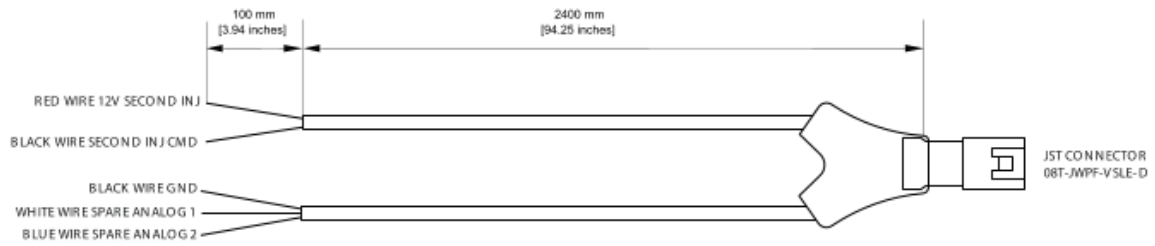

5 Analog channels harness

Part number V02596070

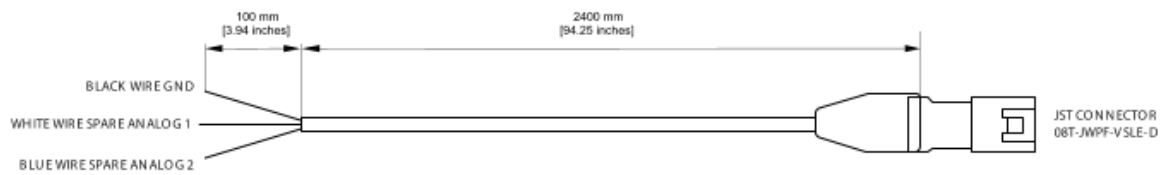

6 Second injection harness

Part number V02596080



Yarara optional cable dimensions and pinout

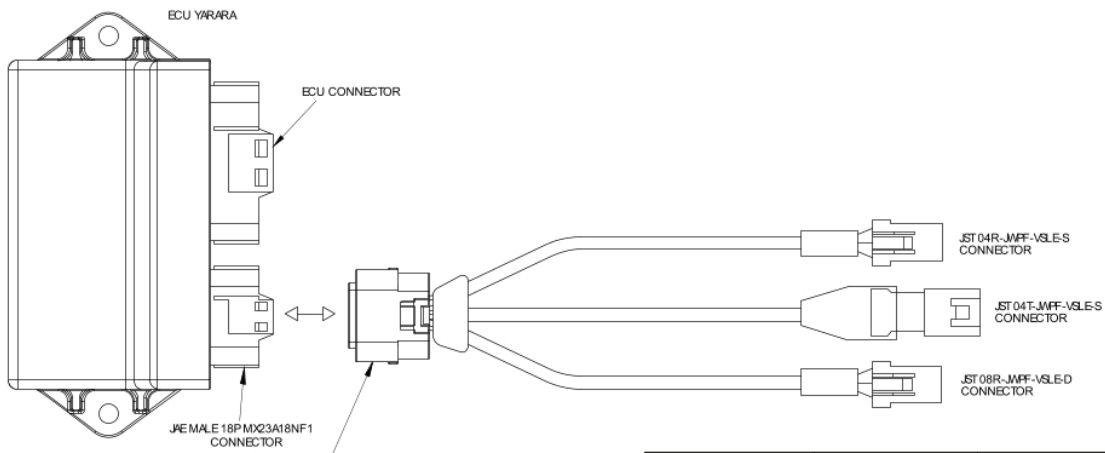
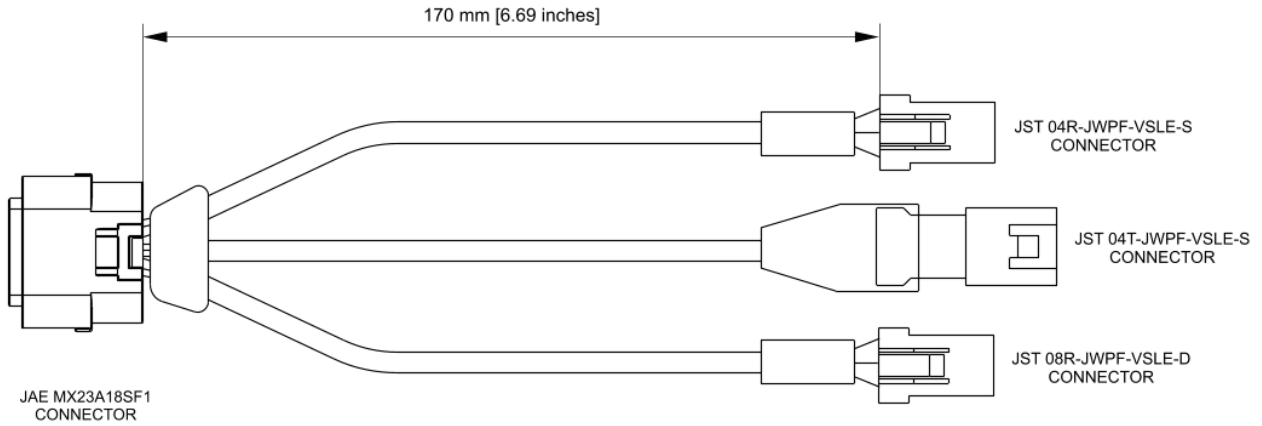

JAE MX23A18SF1 CONNECTOR EXT VIEW	
	1 - 12V SECOND INJ 2 - SECOND INJ CMD 3 - SPARE LOWSIDE 4 - GND 5 - Vref 6 - 12V OUT 7 - GND 8 - CAN CAL HIGH 9 - CAN CAL LOW 10 - NC 11 - NC 12 - NC 13 - SPARE ANALOG 2 14 - SPARE ANALOG 1 15 - CAN EXP HIGH 16 - CAN EXP LOW 17 - GND 18 - 8V IN

JST 04R-JWPF-VSLE-S CONNECTOR EXT VIEW	JST 04T-JWPF-VSLE-S CONNECTOR EXT VIEW	JST 08R-JWPF-VSLE-D CONNECTOR EXT VIEW
1 - GND 2 - CAN EXP HIGH 3 - CAN EXP LOW 4 - 12V OUT	1 - GND 2 - CAN CAL HIGH 3 - CAN CAL LOW 4 - 8V OUT	1 - 12V SECOND INJ 2 - SECOND INJ CMD 3 - SPARE LOWSIDE 4 - GND 5 - SPARE ANALOG 1 6 - SPARE ANALOG 2 7 - Vref 8 - NC

AiM ECUs CAN+External power cable for Solo 2 DL dimensions pinout

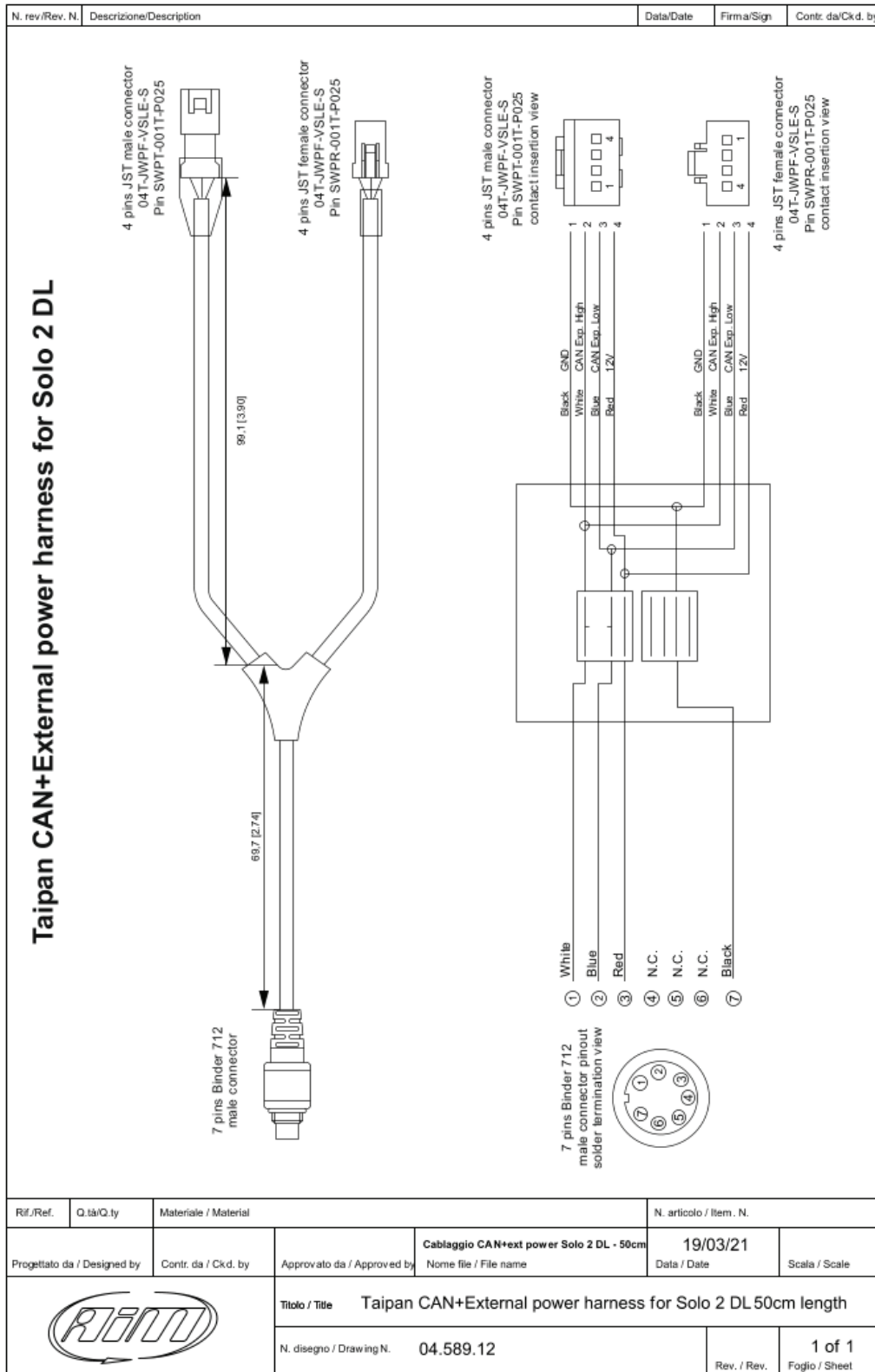



Appendix D – Main terms

Here, a list of terms used in this document and relevant to the Spark software.

Configuration: A Configuration includes the base parameters not directly related to the engine performance. i.e.:

- Set up the second injector if present.
- Set up range of sensor plausibility.
- Set up parameters for the map switch like fuel correction, threshold of RPM to activate the correction chosen.
- Enable/disable launch control.
- Enable/disable pre injection.
- Set up the RPM limiters.
- Set up strategies (The drop sensor, injection, injector phase strategy, neutral strategy, quick shift).
- Set up the VB out (Voltage Battery Output).
- Set up the Can configuration.
- Set up sensors.

Table: The main feature of a table is the presences of one or two breakpoint axis dependent from the type of table (2D: One breakpoint axis, 3D: two breakpoint axis). The table is composed by cells that are a correlation between variables. Here below an example of table.

Map 1 – Fuel.Injection main #1 (ms)

Tps (%/rpm)	250	500	750	1000	1250	1500	1750	2000	2250	2500	2750	3000	3250	3500	3750	4000	4250	4500	4750	5000	5250	5500	5750	6000	6250	6500	6750	7000	7250	7500	7750	8000	8250	8500	8750	9000	
0.0	0.760	0.760	0.760	0.760	0.760	0.760	0.760	0.760	0.760	0.760	0.760	0.760	0.760	0.760	0.760	0.770	0.740	0.640	0.610	0.560	0.500	0.450	0.420	0.380	0.333	0.314	0.285	0.285	0.285	0.285	0.285	0.285	0.285	0.285	0.285	0.285	0.271
2.5	1.180	1.180	1.180	1.180	1.180	1.180	1.180	1.062	1.053	1.044	1.071	1.062	1.053	0.999	0.963	0.945	0.909	0.872	0.828	0.761	0.709	0.655	0.619	0.573	0.546	0.513	0.496	0.453	0.445	0.419	0.403	0.385	0.368	0.343	0.350	0.340	
5.0	1.380	1.380	1.380	1.380	1.380	1.380	1.380	1.242	1.233	1.233	1.242	1.242	1.224	1.197	1.179	1.159	1.113	1.069	1.014	0.978	0.922	0.877	0.832	0.795	0.778	0.752	0.718	0.674	0.648	0.638	0.614	0.599	0.571	0.555	0.550	0.550	
10.0	1.840	1.840	1.840	1.840	1.840	1.840	1.840	1.860	1.940	1.970	1.930	1.850	1.720	1.640	1.550	1.490	1.440	1.410	1.380	1.360	1.330	1.290	1.250	1.231	1.202	1.173	1.144	1.116	1.080	1.063	1.036	1.018	1.014	1.000	0.990		
25.0	3.020	3.020	3.020	3.020	3.020	3.020	3.010	2.990	3.020	3.210	3.350	3.360	3.180	2.960	2.810	2.700	2.630	2.580	2.530	2.490	2.450	2.380	2.350	2.296	2.247	2.228	2.218	2.209	2.200	2.162	2.143	2.124	2.106	2.087	2.080	2.060	
33.0	3.510	3.510	3.510	3.510	3.510	3.510	3.480	3.440	3.470	3.560	3.570	3.610	3.490	3.120	3.030	2.990	2.950	2.910	2.900	2.890	2.890	2.880	2.900	2.910	2.920	2.920	2.910	2.900	2.880	2.840	2.760	2.679	2.632	2.594	2.537	2.480	
50.0	3.660	3.660	3.660	3.660	3.660	3.660	3.620	3.580	3.620	3.760	3.790	3.840	3.610	3.260	3.090	3.060	3.050	3.030	3.070	3.120	3.220	3.330	3.450	3.580	3.680	3.780	3.830	3.880	3.890	3.900	3.880	3.850	3.800	3.740	3.640	3.540	
66.0	3.750	3.750	3.750	3.750	3.750	3.750	3.710	3.670	3.720	3.880	4.000	3.970	3.670	3.350	3.150	3.100	3.100	3.110	3.130	3.150	3.270	3.390	3.530	3.670	3.810	3.960	4.060	4.000	4.220	4.280	4.320	4.340	4.330	4.320	4.250	4.190	
75.0	3.650	3.650	3.650	3.650	3.570	3.460	3.420	3.380	3.430	3.570	3.640	3.610	3.340	3.180	3.010	2.930	2.930	2.930	2.980	3.020	3.150	3.270	3.400	3.530	3.620	3.770	3.880	4.000	4.050	4.170	4.220	4.270	4.270	4.270	4.250	4.240	
100.0	3.570	3.570	3.570	3.570	3.380	3.260	3.230	3.150	3.230	3.380	3.410	3.390	3.210	3.010	2.860	2.720	2.700	2.680	2.680	2.700	2.860	3.030	3.030	3.180	3.260	3.400	3.540	3.680	3.780	3.890	4.060	4.150	4.200	4.250	4.260	4.280	

Map: A Map is the combination of all the parameters governed by the ECU directly related to engine performance and consist of different tables. The main maps are the fuel and ignition, but you can also set up the tables of various strategies and sensors, as we see in the next chapters.

Project: A project is the union of ECU configuration and ECU Maps.



Breakpoint: A breakpoint is the segmentation of the axis. Breakpoints can be equally distributed or increased in specific areas where more accuracy is desired. The trend of breakpoints is monotone.

Entry: An entry is the desired value that the user wants to set in a specific cell in the table.

Engine hour meter: The engine hour meter is the time the engine has been used with this ECU.

Write: means that the data is sent real time to the ECU, but it is not stored in the ECU. As soon as this is turned off, data "written" are cleared. Generally used to tune some entries live.

Flash: means that the data is sent real time to the ECU and it is stored in a permanent memory. Generally used to write a complete map.

TPS: Throttle Position Sensor in %.

ECT: Engine Coolant Temperature.

MAP: Manifold Air Pressure.

Baro: Barometric Air Pressure.

EWT: Engine Water Temperature.

IAT: Intake Air Temperature.

VIGN: Ignition Voltage in V.

Project File: It is the combination of configuration and all the maps.

Valid Map: A map may be not valid in these situations:

- if it is not completely transmitted to the ECU.
- it is not compatible with the firmware version of the ECU.

Running Map: A Running Map is the map actually used by the ECU.

Appendix E – Pre-injection

Pre-injection is intended to avoid starting problems, which could happen in some situations:

- When the water or coolant temperature is low.
- When the geometry of the ducts is not very straight in the direction of the intake valve.
- When the position of the injector is not in line with the intake valve.

The basic purpose of this strategy is to activate, at the beginning of the crank phase, a disposable injection, which goes to wet the intake duct. This allows the subsequent injections not to settle on the ducts, to facilitate starting the motorcycle.

Looking at the image here down:

- Light blue: flywheel signal
- Green: injector command (injects when piloted low)

As can be seen, this strategy, if enabled, intervenes when the ECU is powered at the first rotation of the flywheel to the first tooth detected, regardless of the position of the piston.

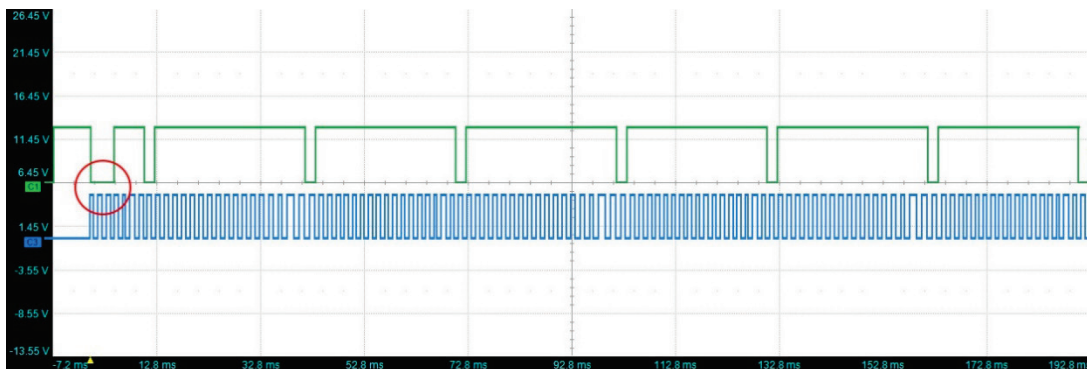

In the red circle, the pre-injection time is highlighted.

This strategy is enabled within the configuration of the project file, in:
Configurations->Parameters->Pre-Injection

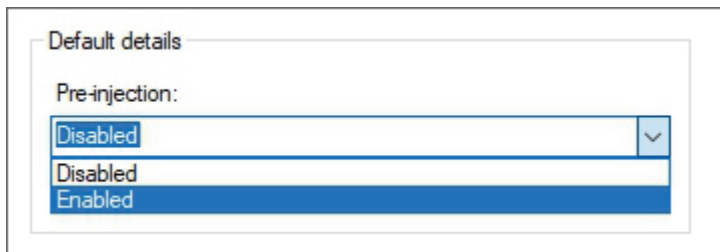

For every map, a pre-injection table is available:

Ms\°C	-15	-3	0	9	14	20	24	34	39	66	82	99
	22	13	9	7	5	4	4	4	3	2	2	2

where the X-axis shows the water temperature, and the entry points are the pre-injection times in msec.



The table above, to be considered as an example, was obtained on an experimental basis, verifying, at the different temperatures at the start-up, how the pre-injection affects the start-up itself. It is easy to see how the pre-injection is more important at low temperatures.

Appendix F – Injection crank correction (%)

The crank injection correction intervenes to facilitate engine starting, when an extra amount of fuel is required than is necessary to keep the engine running in normal conditions. To define this correction, the following table is available:

Table		2D	3D																		
		Map 1 - Fuel.Injection crank correction (%)																			
Cr	0	1	2	3	4	5	6	7	8	9	10	11	12	13	14	15	16	18	120	300	
-40.0	152.0	155.0	158.0	159.0	159.0	158.5	157.8	154.9	150.8	145.7	140.9	137.7	137.7	137.5	137.5	137.5	137.5	141.5	145.5	145.5	
-30.0	142.0	145.0	148.0	149.0	149.0	148.5	147.8	144.9	140.8	135.7	130.9	127.7	127.7	127.5	127.5	127.5	127.5	131.5	135.5	135.5	
-20.0	132.0	135.0	138.0	139.0	139.0	138.5	137.8	134.9	130.8	125.7	120.9	117.7	117.7	117.5	117.5	117.5	117.5	121.5	125.5	125.5	
-10.0	122.0	125.0	128.0	129.0	129.0	128.5	127.8	124.9	120.8	115.7	110.9	107.7	107.7	107.5	107.5	107.5	107.5	111.5	115.5	115.5	
0.0	109.0	113.0	117.0	119.0	120.0	119.5	117.8	114.9	109.8	103.7	95.9	89.7	88.7	88.5	88.5	88.5	89.5	96.5	102.5	102.5	
10.0	97.0	101.0	105.0	108.0	110.0	109.5	108.8	104.9	99.8	91.7	84.9	78.7	75.7	74.5	74.5	74.5	76.5	82.5	88.5	88.5	
20.0	82.0	87.0	92.0	95.0	97.0	97.5	95.8	92.9	86.8	78.7	69.9	64.7	63.7	63.5	63.5	63.5	64.5	67.5	69.5	69.5	
30.0	53.0	59.0	63.0	66.0	67.0	66.5	63.8	59.9	55.8	50.7	45.9	40.7	35.7	33.5	32.5	32.5	32.5	33.5	38.5	45.0	
40.0	26.0	28.0	30.0	31.0	31.0	33.0	38.0	42.0	45.0	46.0	43.0	38.0	25.0	15.0	15.0	15.0	15.0	15.0	17.0	23.0	30.0
50.0	22.0	24.0	27.0	27.0	26.0	27.0	33.0	39.0	43.0	44.0	43.0	38.0	25.0	15.0	15.0	15.0	15.0	15.0	15.0	15.0	30.0
55.0	22.0	24.0	27.0	27.0	26.0	27.0	33.0	39.0	43.0	44.0	43.0	38.0	25.0	15.0	15.0	15.0	15.0	15.0	15.0	15.0	0.0
60.0	20.0	21.0	23.0	24.0	22.0	22.0	28.0	34.0	38.0	39.0	38.0	33.0	25.0	15.0	15.0	15.0	15.0	15.0	15.0	15.0	0.0
65.0	20.0	21.0	23.0	24.0	22.0	22.0	28.0	34.0	38.0	39.0	38.0	33.0	25.0	15.0	15.0	15.0	15.0	15.0	15.0	15.0	0.0
70.0	10.0	9.0	12.5	10.5	10.5	11.0	14.0	17.0	19.0	19.5	19.0	16.5	12.5	7.5	7.5	7.5	7.5	7.5	7.5	7.5	0.0
75.0	0.0	0.0	0.0	0.0	0.0	0.0	0.0	0.0	0.0	0.0	0.0	0.0	0.0	0.0	0.0	0.0	0.0	0.0	0.0	0.0	0.0
80.0	0.0	0.0	0.0	0.0	0.0	0.0	0.0	0.0	0.0	0.0	0.0	0.0	0.0	0.0	0.0	0.0	0.0	0.0	0.0	0.0	0.0
85.0	0.0	0.0	0.0	0.0	0.0	0.0	0.0	0.0	0.0	0.0	0.0	0.0	0.0	0.0	0.0	0.0	0.0	0.0	0.0	0.0	0.0
90.0	0.0	0.0	0.0	0.0	0.0	0.0	0.0	0.0	0.0	0.0	0.0	0.0	0.0	0.0	0.0	0.0	0.0	0.0	0.0	0.0	0.0
95.0	0.0	0.0	0.0	0.0	0.0	0.0	0.0	0.0	0.0	0.0	0.0	0.0	0.0	0.0	0.0	0.0	0.0	0.0	0.0	0.0	0.0
150.0	0.0	0.0	0.0	0.0	0.0	0.0	0.0	0.0	0.0	0.0	0.0	0.0	0.0	0.0	0.0	0.0	0.0	0.0	0.0	0.0	0.0

This table is defined by:

- X axis: number of motor revolutions
- Y axis: engine coolant temperature
- Entry Points: injection time correction percentage

As stated, this strategy works for a limited number of revolutions, as defined in the last value of the X-Axis.

So, once the Start Button is pushed, the injection time will be calculated considering all the following tables:

- the main table "Main table" indicating the injection time,
- the injector battery compensation,
- compensation of the air temperature
- compensation of the barometric pressure
- **the contribution deriving from the crank injection time correction table.**

Let us imagine scrolling this table from left to right at start-up: once the revolutions indicated as the last point on the X axis are finished, the crank phase can be considered finished, and the crank injection correction is

interrupted. At this point, the Injection Time Compensation Table will intervene based on the temperature of the coolant.

So, in the example of the table above, once the 300 revolutions of the engine have been exceeded, the following contributions will intervene:

- the “main” table indicating the injection time
- the injector battery compensation
- compensation of the air temperature
- compensation of the barometric pressure
- **the contribution deriving from the interpolation of the injection time compensation table as a function of the temperature of the coolant.**

The graph below shows an example of strategy intervention and management:

- pink: water temperature
- green: number of motor revolutions
- blue: correction contribution to the crank
- red: water temperature correction contribution
- white: lambda probe value
- orange: RPM

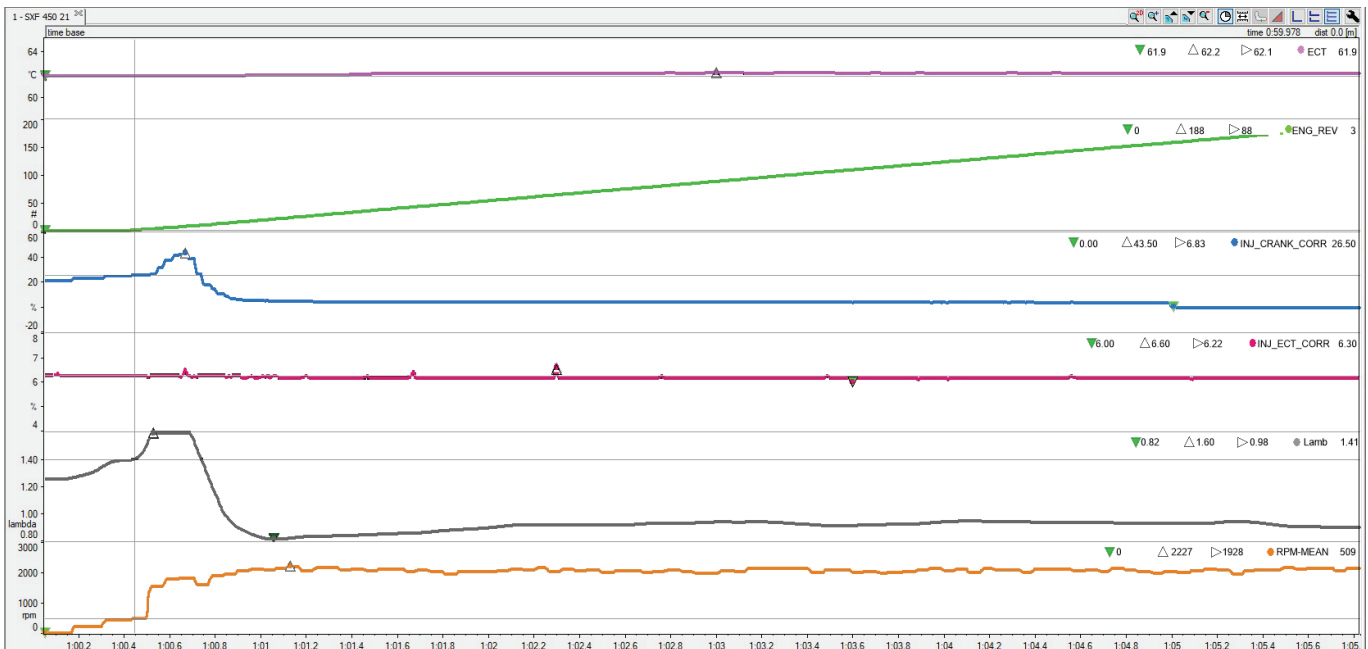

In this example, in the very first revolutions managed by the starter, there is a correction contribution to the crank of 20%. The lambda value will show the effect of the crank - correction a few revolutions after the implementation as shown below.

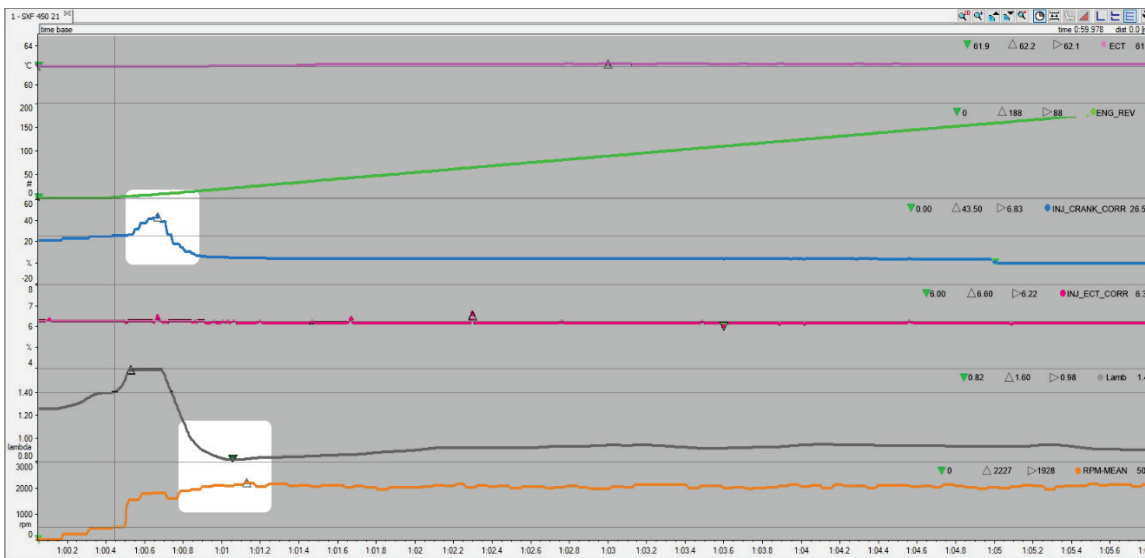

In the picture here above, you may note the crank injection correction peak and the effect of this correction on the lambda level.

The lambda value at this stage is very important:

- if too low "the engine drowns" (too much gasoline) and it will not start, with the risk of wetting the spark plug
- if it is too high, the gasoline will not be enough to start the engine.

After the crank, the engine is at idle, and the lambda value will stabilize at the desired target value, as shown in the image below.

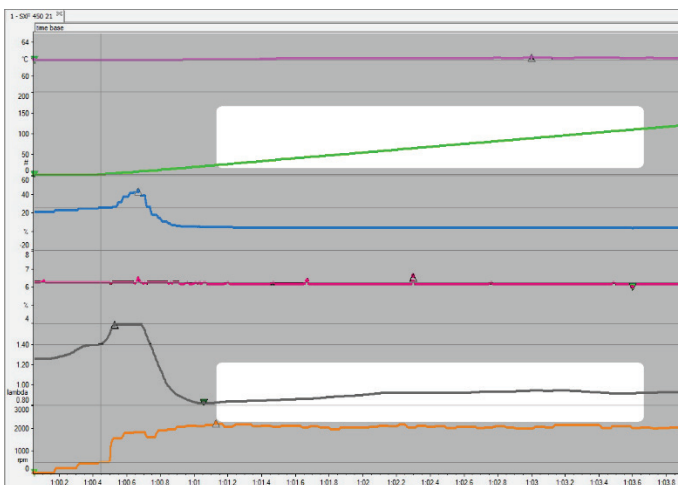

The last image shows exactly when the correction of the injection to the crank stops, and the correction is managed in accordance with the coolant temperature.

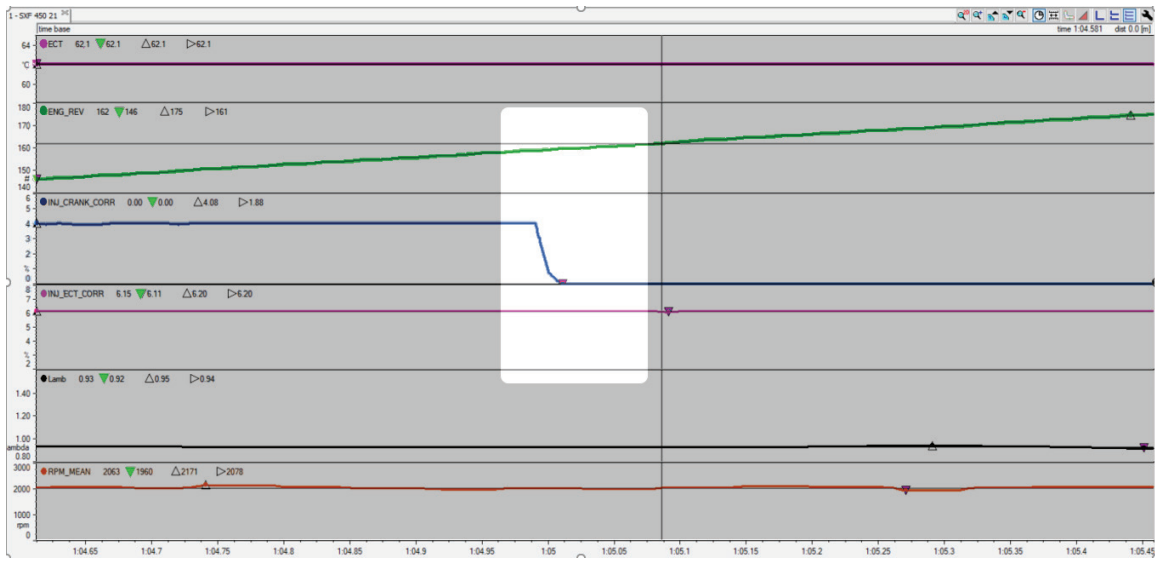

Appendix G – Injection N battery correction

One of the most important parameters for the engine control is the injection time, i.e., the duration of the injector command pulse so that the desired amount of petrol enters the combustion chamber of the engine. The injection time is calculated based on parameters, some of which depend on the characteristics of the injector, while others depend on other factors, such as water temperature, air, barometric pressure, etc. Here we see how the injector power supply voltage affects the opening time of the injector during the injection.

The injector can be schematized as in this image:



This is a very simple circuit consisting of an inductor and a resistor. The inductive component, depending on the applied voltage, will make the injector open more or less quickly. Injector manufacturers always provide a table such as this one below, which represents the characterization of the injector itself. The table is very simple:

G2-99-0123

350 CC/MIN - 32 LBS/HR

EV6/EV14/USCAR electrical connector



Fuel Pressure		Voltage Offset					Flow Rate	
PSID	BAR	8 Volts	10 Volts	12 Volts	14 Volts	16 Volts	cc/min	lbs/hr
43.5	3.00	1.890	1.530	1.120	0.750	0.490	309	29
45	3.10	1.935	1.518	1.095	0.733	0.485	321	31
50	3.44	1.980	1.505	1.070	0.715	0.480	334	32
55	3.79	2.025	1.492	1.045	0.697	0.475	346	33
60	4.13	2.070	1.480	1.020	0.680	0.470	358	34
65	4.48	2.190	1.555	1.060	0.710	0.500	371	35
70	4.82	2.310	1.630	1.110	0.740	0.530	383	36
75	5.17	2.370	1.675	1.135	0.765	0.550	396	38
80	5.51	2.430	1.720	1.170	0.790	0.570	408	39
85	5.86	2.485	1.765	1.210	0.820	0.595	420	40
90	6.20	2.540	1.810	1.250	0.850	0.620	433	41
95	6.55	2.600	1.855	1.280	0.875	0.635	449	43
100	6.89	2.660	1.900	1.310	0.900	0.650	464	44



STANDARD

Voltage offset values are in milliseconds ms - 1ms = 1000us

At a certain fuel pressure (column 1/2) to obtain the desired amount of fuel (column 8/9), the injector must remain open for the time in msec depending on the power supply voltage indicated in the various "Voltage Offset" columns (columns 3/7).

The overall injection time driven by the ECU will therefore be given by considering, in addition to the set of contributions on the main table, also from this "offset" strictly dependent on the intrinsic characteristics of the injector.

Appendix H – Injection BAP correction

- BAP means Barometric Air Pressure, the weight exerted on the Earth by the air present in the atmosphere. The barometric pressure is therefore the pressure exerted at a certain point by the column of air that goes from the highest point of the atmosphere to the ground. It is obvious that the higher you move, the lower is the barometric pressure value.
- AFR means Air Fuel Ratio, that is the ratio between the intake air and the injected gasoline.

On a beautiful day at sea level the barometric pressure is 1020mBar, and a motorcycle at idle speed will have an AFR of 0.89. If you go up to 2500 m (8000 ft), where the air pressure is 780mBar, how will the lambda change? Given the premises described above, and knowing that as the height increases, the weight of the air column decreases, there is less air at altitude and therefore the AFR ratio decreases. If in these conditions we left the injected petrol unchanged, our engine would get greased, with even the risk of being shut down due to too much injected petrol.

Injection BAP correction serves to avoid this effect and acts by decreasing the percentage of petrol injected as the barometric pressure decreases in order to maintain the target lambda value.

This compensation table is very simple and is shown below:

%\mbar	400	450	500	550	600	650	700	750	800	850	900	950	1000	1050	1100	1200
	-50.0	-50.0	-50.0	-45.0	-40.0	-37.0	-32.0	-27.0	-22.0	-17.0	-5.0	0.0	0.0	0.0	5.0	10.0

The pressure value in mBar is shown on the X axis, and the percentage correction on injected petrol as an entry point value.

Appendix I – Transient management

Managing transient throttle enrichment of an off-road motorcycle is one of the most critical calculations the ECU performs and represents the core of all its strategies. The effectiveness and speed of implementation are vital in providing a reliable response to the rapid transient throttle opening and closing.

In motocross applications, the transient opening and closing of the throttle represents 80-85% of the time on track; the throttle is closed for the remaining 15-20%.

Closed-loop tuning with Lambda or AFR is not a practical strategy in motocross because of the amount of transient throttle. However, using a Lambda sensor is useful for validating the effectiveness of transient throttle enrichment strategies.

Transient corrections are unique to every map in the Spark tuning software. Four transient correction tables are available for each map; a throttle opening and closing table for both injection and ignition.

- Injection corrections are a percentage of injector pulse duration.
- Ignition corrections are an offset in degrees of spark timing.

Please review the sample transient throttle correction tables below.

Injection correction table for transient throttle opening.

Injection correction for opening throttle transients

Tps (%)	2.0	3.5	4.5	9.0	15.0	20.0	25.0	30.0	35.0	37.5	40.0	45.0	50.0	60.0	70.0	80.0
Opening speed (%/s)	190	300	320	360	360	650	650	650	650	650	650	650	650	650	650	650
Correction (%)	5.0	5.0	8.0	10.0	15.0	15.0	20.0	25.0	30.0	30.0	30.0	30.0	30.0	20.0	20.0	20.0
Correction time (r)	5	5	5	5	5	5	5	5	5	5	5	5	5	5	4	4

Injection correction for closing throttle transients

Tps (%)	15.0	25.0	30.0	32.0	35.0	38.0	43.0	50.0	54.0	57.0	60.0	65.0	70.0	75.0	80.0	85.0
Closing speed (%/s)	-820	-750	-700	-688	-664	-650	-450	-450	-450	-450	-410	-400	-400	-400	-400	-400
Correction (%)	-40.0	-40.0	-40.0	-45.0	-45.0	-45.0	-45.0	-45.0	-45.0	-45.0	-45.0	-45.0	-45.0	-45.0	-45.0	-45.0
Correction time (r)	6	6	6	6	5	5	5	5	5	4	4	4	4	3	3	3

Ignition correction for opening throttle transient

Tps (%)	2.0	3.5	4.5	9.0	15.0	20.0	25.0	30.0	35.0	37.5	40.0	45.0	50.0	55.0	60.0	70.0
Opening speed (%/s)	190	300	320	600	850	950	1050	1100	1150	1200	1250	1300	1350	1400	1450	1520
Correction advance (°)	0.0	0.0	0.0	0.0	0.0	0.0	0.0	0.0	0.0	0.0	0.0	0.0	0.0	0.0	0.0	0.0
Correction time (r)	1	1	1	1	1	1	1	1	1	1	1	1	1	1	1	1

Ignition correction for closing throttle transient

Tps (%)	20.0	25.0	30.0	32.0	35.0	38.0	43.0	50.0	54.0	57.0	60.0	65.0	70.0	75.0	80.0	85.0
Closing speed (%/s)	-820	-750	-700	-688	-664	-650	-630	-570	-540	-470	-410	-400	-400	-400	-400	-400
Correction advance (°)	0.0	0.0	0.0	0.0	0.0	0.0	0.0	0.0	0.0	0.0	0.0	0.0	0.0	0.0	0.0	0.0
Correction time (r)	1	1	1	1	1	1	1	1	1	1	1	1	1	1	1	1

Table Details:

The first column is the same structure across all tables:

- **TPS (%)** is the position of the throttle.
- **Opening/Closing Speed (% / s)** is the derivative of throttle position speed (**DTPS**), or how fast the throttle is opened or closed. It's important to note that the value is a minimum threshold for the correction to be applied.
- DTPS is calculated as $v = (x2 - x1) / t$ where:
 - v = speed
 - $x2$ = final throttle position
 - $x1$ = initial throttle position
 - t = time interval

During throttle opening, $x2$ will be greater than $x1$; therefore, the speed will be a positive value.

During throttle closing, $x2$ will be less than $x1$; therefore, the speed will be a negative value.

A DTPS value of 100%/s means that the throttle position moves from 0 to 100% in ONE second.

If the rider opens the throttle faster, the DTPS value grows. A DTPS of 200%/s means that the rider opens the throttle from 0 to 100% in half a second (100 / 0.5). Similarly, a throttle twist from 20 to 70% in half a second, a 50% change, is 100%/s (50 / 0.5)

A negative value means that the rider is closing the throttle. For example, a value of -500%/s means that the rider has closed the throttle, from 100% to 0% in 0.2 secs (-100 / 0.2).

Important! The DTPS is the qualifying threshold that must be met to apply the correction.

A data logger is required to record the value of the DTPS while the rider is on track. Analysis of the data will allow recursive fine-tuning of the transient enrichment strategy. AiM offers several data loggers, and for motocross, the Solo2 DL is the most suitable choice.

• Correction indicates the type of correction:

- On the injection table, it indicates the percentage of correction to the injector pulse duration.
- On the ignition table, it indicates the offset in degrees of spark timing.

• Correction time (r) is the number of engine revolutions for which the corrections are applied. For example, at 12,000 RPM, the engine rotates 200 times per second, so every revolution is five (5) milliseconds (1000 / 200). To continue with the example, if the 'correction time (r)' is set to 5 revolutions, the correction will apply for a total of 25 milliseconds (5 revs x 5 msec).

Purpose:

The purpose of the transient throttle strategy is to avoid:

1) The engine stalling during the rapid opening of the throttle.

A rapid opening of the throttle will result in a large volume of air rushing into the intake with insufficient fuel to burn. Not having enough fuel to burn, the air pressure will rapidly increase in the intake duct, the



lambda value will reach a lean peak, and the engine will hesitate and possibly stall. This effect is more evident at low RPM.

2) Engine hesitation after the rapid closing of the throttle.

When the rider quickly closes the throttle, a quantity of scheduled fuel is still delivered into the intake. The extra fuel delivered during the closing of the throttle may result in a puddle of fuel in the intake. This extra fuel can create a rich condition when the throttle is again opened, making for a hesitant engine that lacks a good throttle response.

Minimizing these two conditions will result in a predictable, ready, and consistently snappy motorcycle. Please review the injector transient correction table and corresponding data below to see this strategy at work

Tps (%)	2.0	4.5	9.0	15.0	20.0	25.0	30.0	35.0	37.5	40.0	45.0	50.0	55.0	60.0	70.0
Opening speed (%/s)	190	320	360	360	650	650	650	650	650	650	650	650	650	650	650
Correction (%)	5.0	8.0	10.0	15.0	15.0	20.0	25.0	30.0	30.0	30.0	30.0	30.0	20.0	20.0	20.0
Correction time (r)	5	5	5	5	5	5	5	5	5	5	5	5	5	4	4

Reading this table from top to bottom, looking at the area circled, we see:

- 1) An assumed value of 10% throttle opening, falling between 9 and 15% in the first row.
- 2) A throttle opening speed threshold of 360% per second in the second row.
- 3) A fuel correction between 10-15%, to be linearly interpolated, in the third row.
- 4) A correction time of 5 engine revolutions in the final row.

These screen captures of logged data give visual details of the transient throttle enrichment strategy at work.

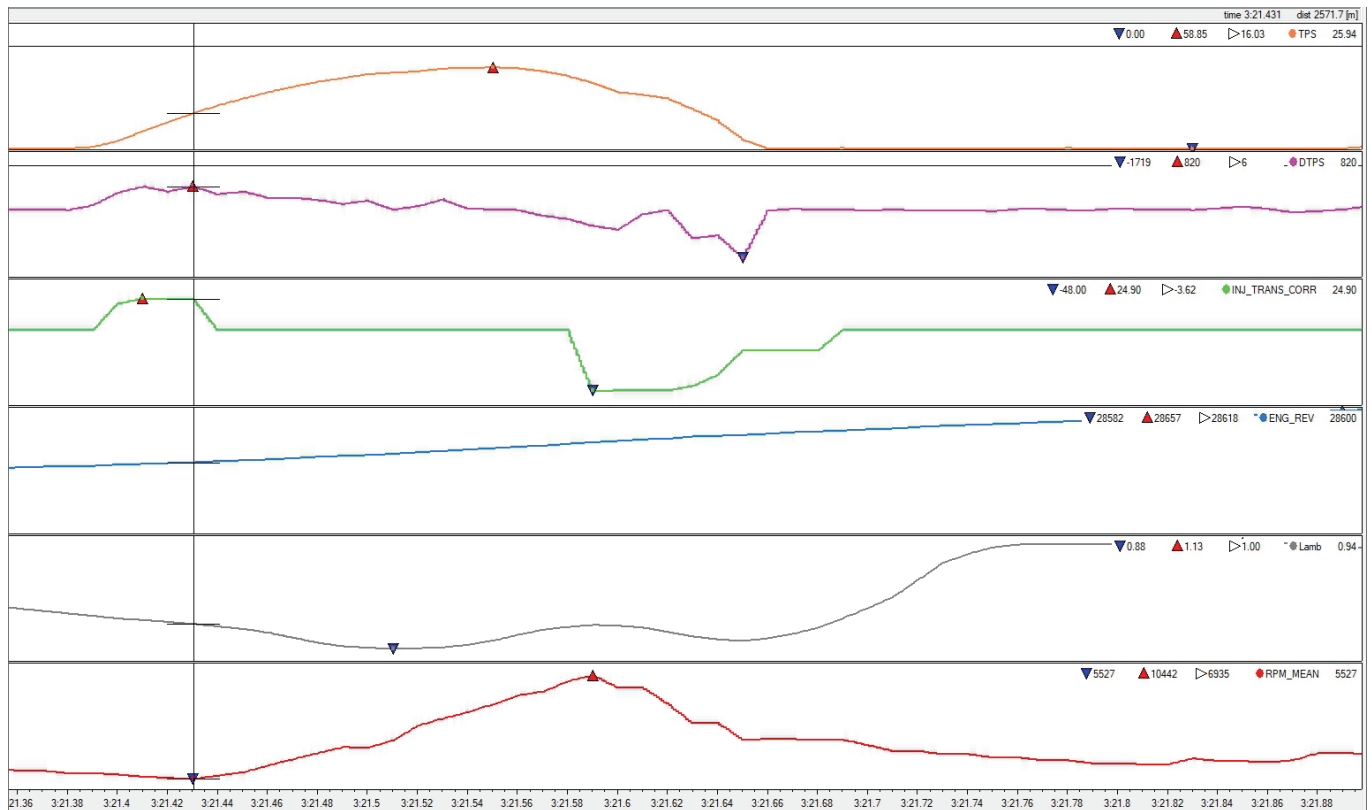

- Orange curve: TPS
- Purple curve: DTPS (throttle opening speed)
- Green curve: INJ_TRANS_CORR (% injection correction of transients)

- Blue curve: ENG_REV (motor revolution counter)
- Grey curve: lambda value
- Red curve: RPM

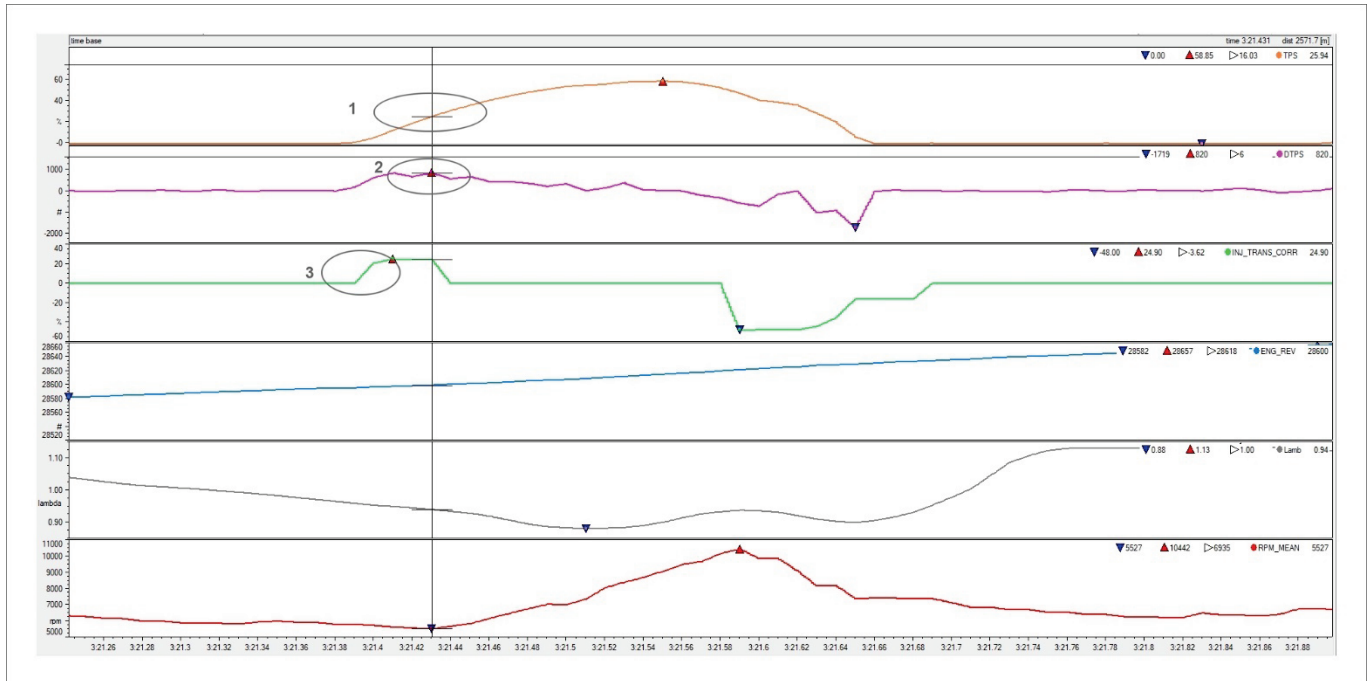

Above we see the data plotted over time, zoomed full screen to about 0.5 seconds.

- Circle 1 is the throttle opening.
- Circle 2 shows an increased throttle opening speed (DTPS) that exceeds the threshold value of the opening speed value expressed in the table to apply a transient injector correction.
- Circle 3 shows the percentage of injector pulse width correction applied.

The correction is recalculated 200 times per second: when, during an opening, the DTPS value is no longer higher than the value interpolated from the table, the correction remains for the number of revolutions set in the same table. The graph below shows this effect.

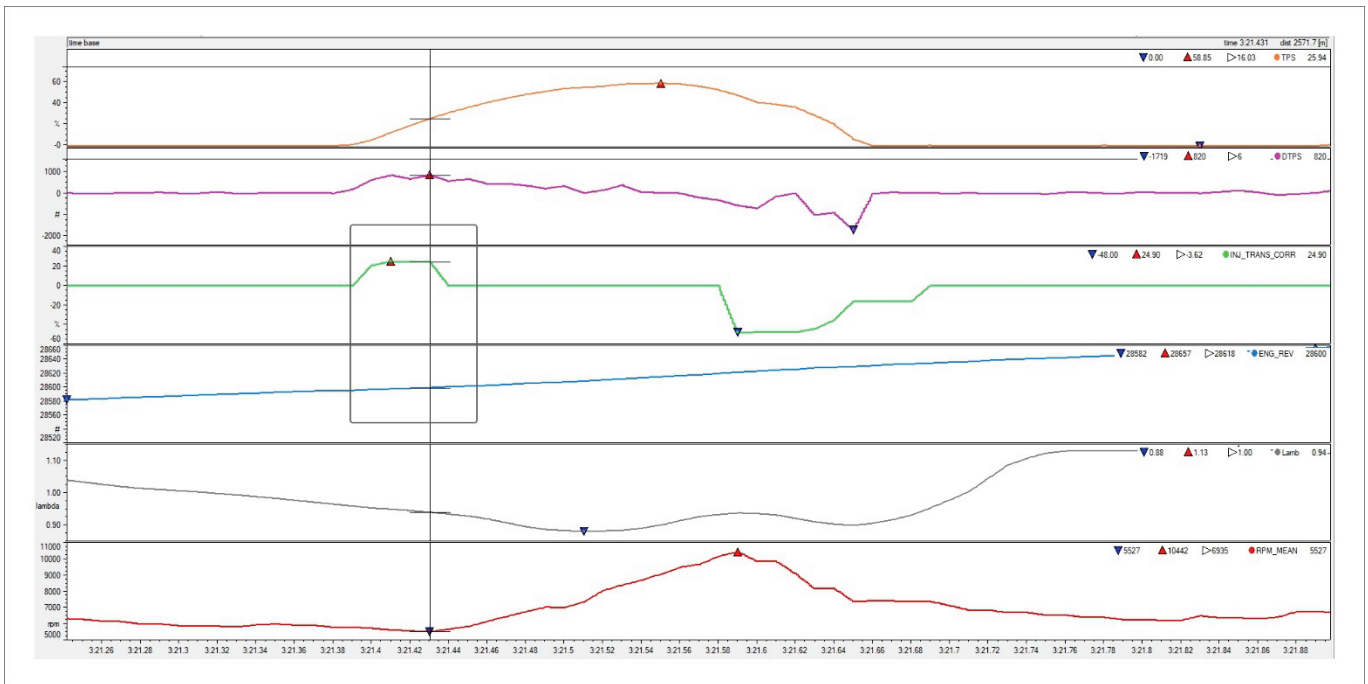

The rectangle in this graph highlights how the contribution of the injector correction (green curve) at a certain point remains constant for the number of motor revolutions set in the correction time (blue graph).

The moment the throttle is released, the throttle lock injection transient correction table will be used. You can check the result by observing the lambda value, highlighted in the rectangle in the image above.

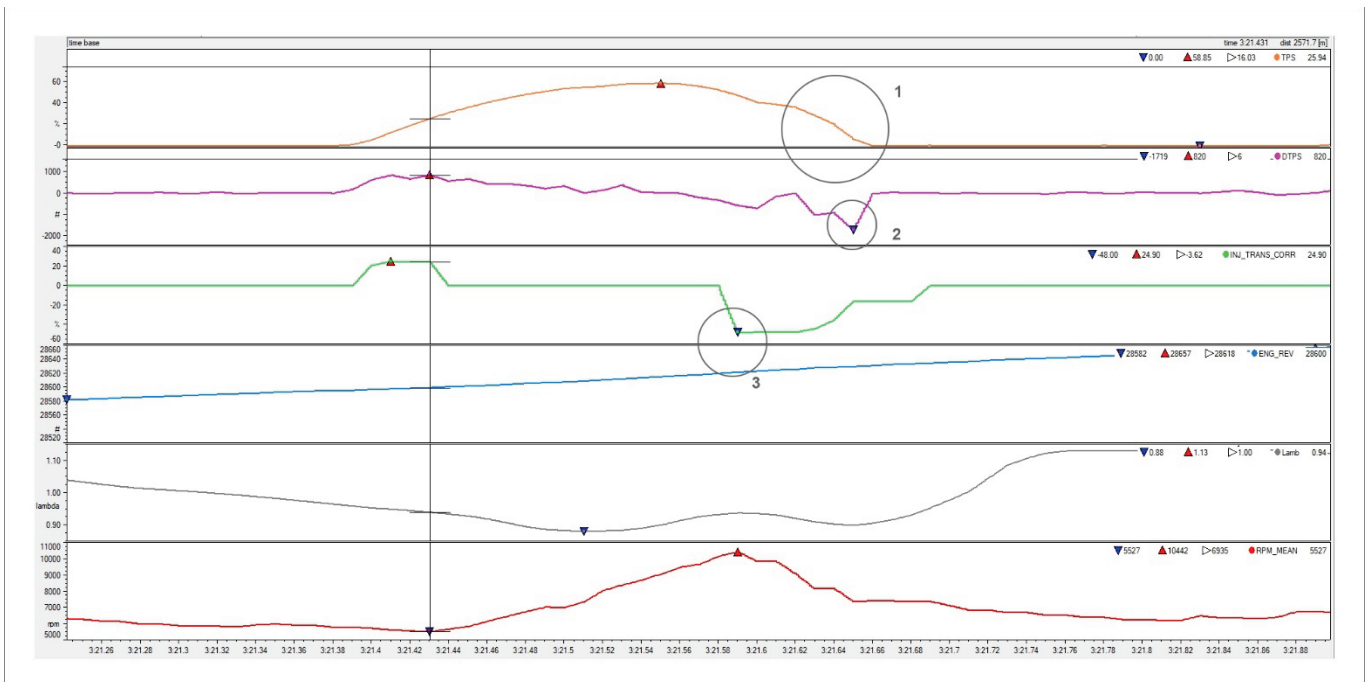

When the rider closes the throttle and the DTSP closing speed exceeds the threshold value from the injection correction table for transient throttle closing in the negative direction, the fuel percentage correction is applied for the number of engine revolutions expressed in the table. The above image shows the throttle closure process (orange graph) with the effects of DTSP (purple) and injection percentage correction (green).



It is easy to see that it is necessary to add fuel during the throttle opening to prevent the engine from stalling, while during the closing, it is essential to remove fuel.

Here we can also observe that:

- The throttle went from 0 to 58% in 0.16 sec
- The RPM value went from 5527 to 10442 in the same period
- The Lambda value remained between 0.88 and 0.96 λ without rich or lean peaks during the transient conditions.

Similar transient throttle corrections can be made for ignition timing; increasing the advance by adding a positive offset assists in increasing engine RPM to avoid a stall. However, the ignition offset is generally absent, and only in some rare cases is it appropriate to introduce a negative offset.



Appendix J – CAN Protocols

User CAN Protocol

Can Bus Speed: 1 Mbit Endianless: Big Endian

CAN ID	B0	B1	B2	B3	B4	B5	B6	B7
0x402			TPS		Gear			
0x403	Battery Voltage							
0x404	ECT		IAC		ECU T			
0x405	RPM							
0x40B	Usage Time Sec		Usage Time Min					
0x40C	DTPS		Inj Trans Corr		Ign Trans Corr		Eng Flag	
0x40D							Eng State	
0x40E					Map Sel		Launch State	
0x40F	Eng Diag HH	Eng Diag HL	Eng Diag LH	Eng Diag LL	Analog Diag HH	Analog Diag HL	Analog Diag LH	Analog Diag LL
0x410	Eng Rev							
0x411	Drop V		Spare CH 1		Spare CH 2			

Channel name	Gain	Offset	Sign	Measure unit
TPS	0,1	0	unsigned	%
GEAR	1	0	unsigned	#
Battery Voltage	1	0	unsigned	mV
ECT	0,1	0	signed	C
IAT	0,1	0	signed	C
ECU T	1	0	signed	C
RPM	1	0	unsigned	rpm
USAGE TIME SEC	1	0	unsigned	s
USAGE TIME MIN	1	0	unsigned	min
DTPS	1	0	signed	#
INJ TRANS CORR	0.1	-100	signed	%
IGN TRANS CORR	0.1	0	signed	deg
ENG FLAG	1	0	unsigned	#
MAP SEL	1	0	unsigned	#
LAUNCH STATE	1	0	unsigned	#
ENG DIAG HH	1	0	unsigned	#
TPS	0,1	0	unsigned	%
GEAR	1	0	unsigned	#
DTPS	1	0	signed	#
ENG DIAG HL	1	0	unsigned	#
ENG DIAG LH	1	0	unsigned	#
ENG DIAG LL	1	0	unsigned	#
ANALOG DIAG HH	1	0	unsigned	#
ANALOG DIAG HL	1	0	unsigned	#
ANALOG DIAG LH	1	0	unsigned	#
ANALOG DIAG LL	1	0	unsigned	#



ENG REV	1	0	unsigned	#
DROP V	1	0	unsigned	mV
SPARE CH 1	1	0	unsigned	mV
SPARE CH 2	1	0	unsigned	mV

Tuner CAN Protocol

Can Bus Speed: 1 Mbit Endianless: Big Endian

CAN ID	B0	B1	B2	B3	B4	B5	B6	B7
0x400	MAP CNT		TPS CNT		BATTERY CNT		ECT CNT	
0x401	GEAR CNT		IAT CNT					
0x402	MAP		TPS		GEAR		RPM 360	
0x403	BATTERY						VREF	
0x404	ECT		IAT		ECU T		BAROMETRIC P	
0x405	RPM		IGN ADV		IGN BASE ADV		INJ TIME	
0x406	IGN ECT CORR		IGN IAT CORR		INJ ECT CORR		INJ IAT CORR	
0x407	INJ1 BASE PHASE		INJ BASE TIME		INJ1 PHASE		INJ1 TIME	
0x408	SMOT ERR CNT		INJ CRANK CORR		INJ1 BATT CORR		TRIM CORR	
0x409	IGN BAP CORR		INJ BAP CORR					
0x40A	INJ1 PERC		INJ2 PERC				INJ2 PHASE	
0x40B	INJ2 TIME		INJ2 BATT CORR		USAGE TIME SEC		USAGE TIME MIN	
0x40C	DTPS		INJ TRANS CORR		IGN TRANS CORR		ENG FLAG	
0x40D	IGN TC CORR		INJ TC CORR		ENG POS		ENG STATE	
0x40E	REF TIME				MAP SEL		LAUNCH STATE	
0x40F	ENG DIAG HH	ENG DIAG HL	ENG DIAG LH	ENG DIAG LL	ANALOG DIAG HH	ANALOG DIAG HL	ANALOG DIAG LH	ANALOG DIAG LL
0x410	ENG REV				RPM MEAN ACC			
0x411	DROP V		SPARE CH 1		SPARE CH 2			
0x412	LAMBDA							

Channel name	Gain	Offset	Sign	Measure unit
MAP CNT	1	0	unsigned	#
TPS CNT	1	0	unsigned	#
BATTERY CNT	1	0	unsigned	#
ECT CNT	1	0	unsigned	#
GEAR CNT	1	0	unsigned	#
IAT CNT	1	0	unsigned	#
MAP	1	0	unsigned	mBar
TPS	0,1	0	unsigned	%
GEAR	1	0	unsigned	#
RPM 360	1	0	unsigned	rpm
BATTERY	1	0	unsigned	mV
VREF	1	0	unsigned	mV
ECT	0,1	0	signed	C
IAT	0,1	0	signed	C
ECU T	1	0	signed	C



BAROMETRIC P	1	0	unsigned	mBar
RPM	1	0	unsigned	rpm
IGN ADV	0,1	0	signed	deg
IGN BASE ADV	0,1	0	signed	deg
INJ TIME	1	0	unsigned	us
IGN ECT CORR	0,1	0	signed	deg
IGN IAT CORR	0,1	0	signed	deg
INJ ECT CORR	0,1	-100	signed	%
INJ IAT CORR	0,1	-100	signed	%
INJ1 BASE PHASE	0,1	-360	signed	deg
INJ BASE TIME	1	0	unsigned	ms
INJ1 PHASE	0,1	-360	signed	deg
INJ1 TIME	1	0	unsigned	ms
SMOT ERR CNT	1	0	unsigned	#
INJ CRANK CORR	0,1	-100	signed	%
INJ1 BATT CORR	1	0	unsigned	ms
TRIM CORR	0,1	-100	signed	%
IGN BAP CORR	0,1	0	signed	deg
INJ BAP CORR	0,1	-100	signed	%
INJ1 PERC	0,1	0	unsigned	%
INJ2 PERC	0,1	0	unsigned	%
INJ2 PHASE	0,1	-360	signed	deg
INJ2 TIME	1	0	unsigned	us
INJ2 BATT CORR	1	0	unsigned	us
USAGE TIME SEC	1	0	unsigned	s
USAGE TIME MIN	1	0	unsigned	min
DTPS	1	0	signed	#
INJ TRANS CORR	0,1	-100	signed	%
IGN TRANS CORR	0,1	0	signed	deg
ENG FLAG	1	0	unsigned	#
IGN TC CORR	0,1	0	signed	deg
INJ TC CORR	0,1	0	signed	deg
ENG POS	1	0	unsigned	#
ENG STATE	1	0	unsigned	#
REF TIME	1	0	unsigned	us
MAP SEL	1	0	unsigned	#
LAUNCH STATE	1	0	unsigned	#
ENG DIAG HH	1	0	unsigned	#
ENG DIAG HL	1	0	unsigned	#
ENG DIAG LH	1	0	unsigned	#
ENG DIAG LL	1	0	unsigned	#



ANALOG DIAG	1	0	unsigned	#
ANALOG DIAG	1	0	unsigned	#
ANALOG DIAG	1	0	unsigned	#
ANALOG DIAG LL	1	0	unsigned	#
ENG REV	1	0	unsigned	#
RPM MEAN ACC	1	0	signed	#
DROP V	1	0	unsigned	mV
SPARE CH 1	1	0	unsigned	mV
SPARE CH 2	1	0	unsigned	mV
LAMBDA	0.001	0	Unsigned	lambda



Appendix K – Malfunctioning Indicator Lamp (MIL) – Taipan only

From Taipan firmware version 0.5.19 all bikes equipped with a MIL (Malfunction indicator Lamp) a visual indicator of malfunctions is available. According to the settings here below explained the type of error will be identified:

- 1 Flash -> Primary Injector Failure
- 2 Flashes -> Secondary Injector Failure (stock on the bikes that feature it)
- 3 Flashes -> MAP (manifold air pressure) sensor failure
- 4 Flashes -> TPS (throttle position sensor) sensor failure
- 5 Flashes -> ECT (engine coolant temperature) sensor failure
- 6 Flashes -> IAT (Intake air temperature) sensor failure
- 7 Flashes -> GEAR sensor (where available) failure